

Gordon Containment Floor Mount Rigid Wall Operation & Maintenance Manual

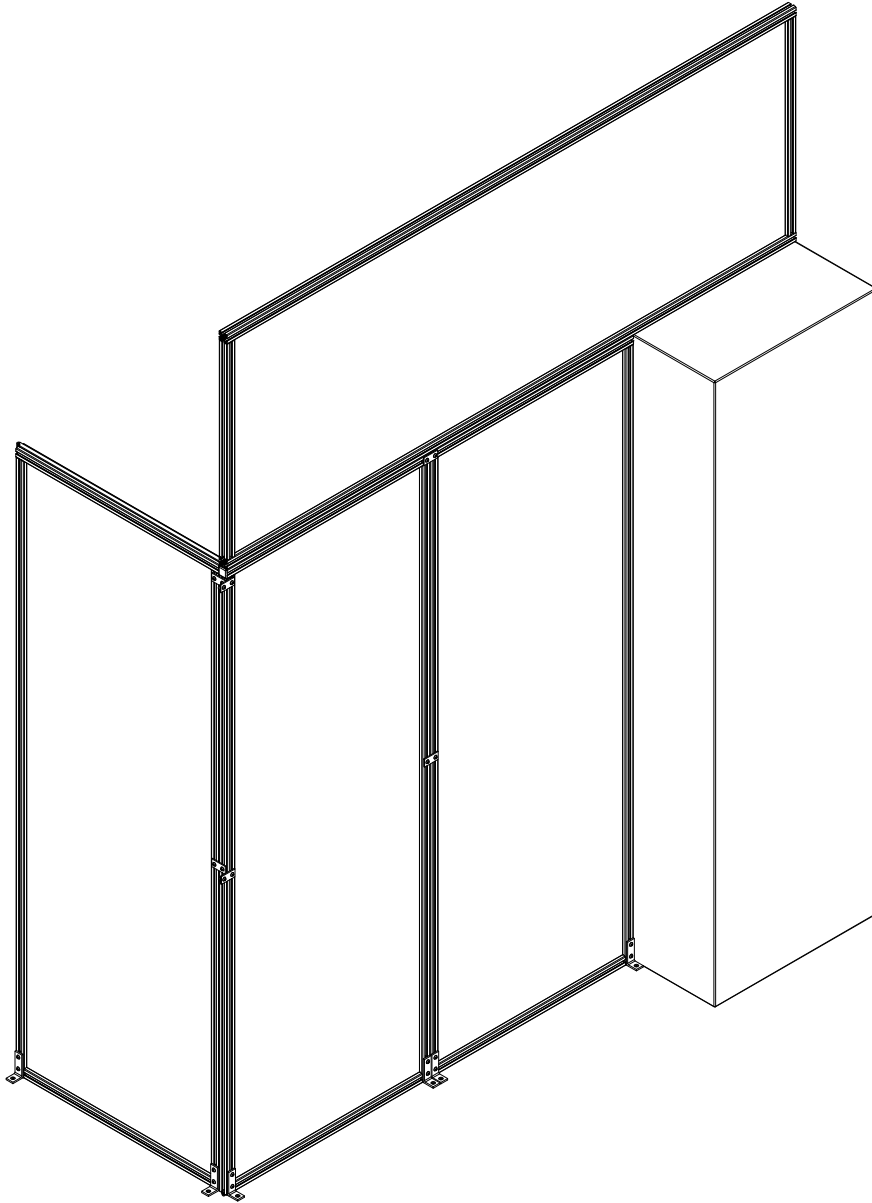

H:\DWG\LAYOUTS\DATA CENTERS\CONTAINMENT WALL\FM_INSTRUCTIONS

GORDON[®]
ARCHITECTURAL+ENGINEERED SOLUTIONS

5023 Hazel Jones Rd.
Bossier City, LA 71111
800.747.8954
GORDON-INC.COM
sales@gordon-inc.com

TITLE

GORDON CONTAINMENT
O & M MANUAL

Safety & Handling

When unpacking the rigid walls and components, be careful not to scratch the aluminum frame and the Lexan. They have been carefully packaged and inspected before crating. Inspect all components and be sure all required hardware is included for assembly.

Use only the proper and recommended tools for all assembly procedures as well as installation of the Rigid Walls in and around the cabinets.

Do not lean the Rigid Walls against walls, cabinets or posts where there is a chance for them to fall and become damaged.

All movement and assembly requires two persons for safety and protection of the Rigid Walls being installed and the equipment around them.

Tools List

$\frac{5}{16}$ " Hex Nut Driver Bit	Extension Cord	Hammer	$\frac{1}{4}$ " Drill Bit (Masonry or standard)
Rubber Mallet	4' Level	Tape Measure	Pencil
Step Ladder	Phillips Drill Bit	Drill	$\frac{5}{32}$ " T-Handle Hex Wrench

General Installation Tips and Tricks

- Put together a corner section of Rigid Wall, or against the wall or cabinets.
- Mount the Rigid Walls to the racks or wall as needed to provide rigidity so rigid wall does not flex due to differential pressures of the ventilation system.
- Panels will be snug between cabinets. If they are too snug, then remove the foam bulb.
- If T-nut for mounting the hardware cannot be slid into the slot from the end, the T-nut can be inserted directly into the slot by placing a portion of the foam wrapping material in the slot and then placing the T-nut in front of the foam. This will provide backing for the T-nut and hold it in position while inserting the screw. Once the screw is threaded onto the T-nut, hold the foam material and slide the T-nut off the foam, then remove the foam out of the slot.

Inside Corner Application

Use either the Inside Corner Application (this page) or Outside Corner Application (next page) depending upon the determined application when this job was ordered.

- Inside Corner Installation using a corner bracket (Detail A & B).
 - Ensure corners are tight and properly aligned while tightening corner bracket using $\frac{5}{32}$ " T-Handle wrench.
 - 1 each corner bracket on top and bottom rail.
- Place End Caps on the aluminum extrusion for a finished off look on the outside corners (see Detail C on next page).

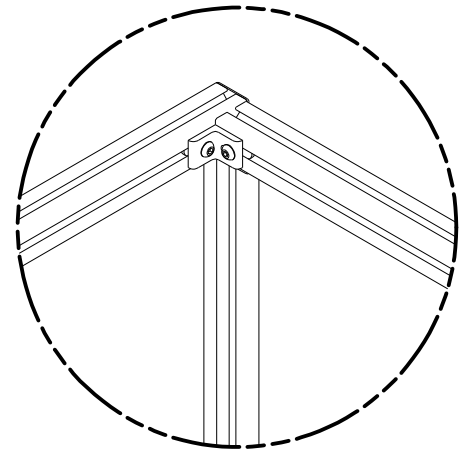
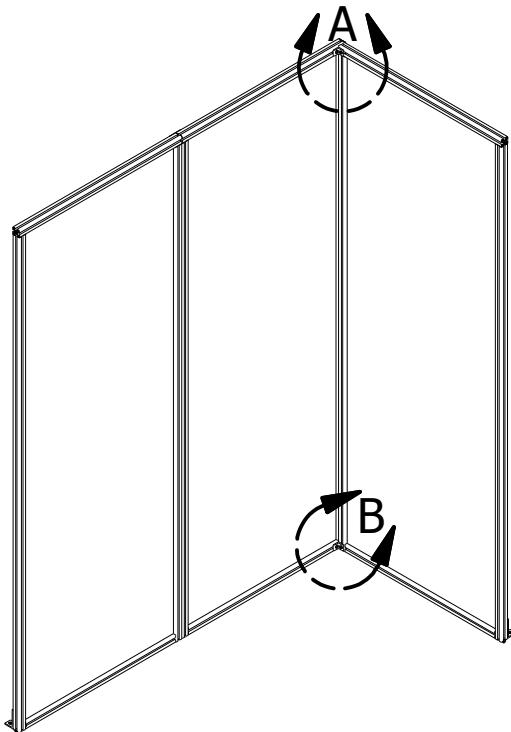

DETAIL A

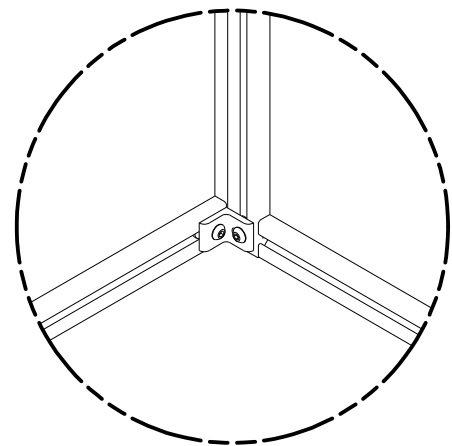

DETAIL B

Outside Corner Application

- Place Joining Strips on the outside corner per Detail C & D below.
 - Ensure corners are tight and properly aligned while tightening Joining Strip using $\frac{5}{32}$ " T-Handle wrench.
 - 2 each Joining Strips on the top and the middle of Rigid Wall .
- Place End Caps on the ends of the aluminum extrusion for a finished off look on the outside corners (see Detail C below).

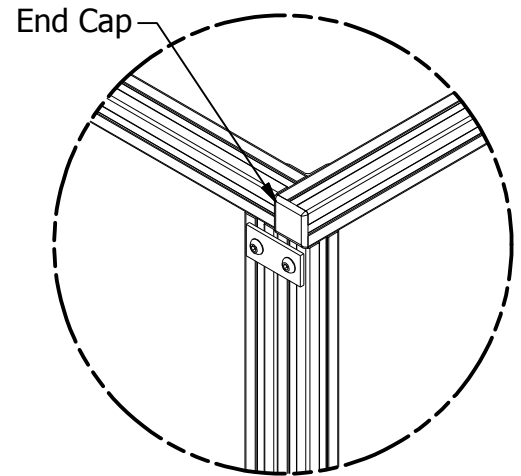
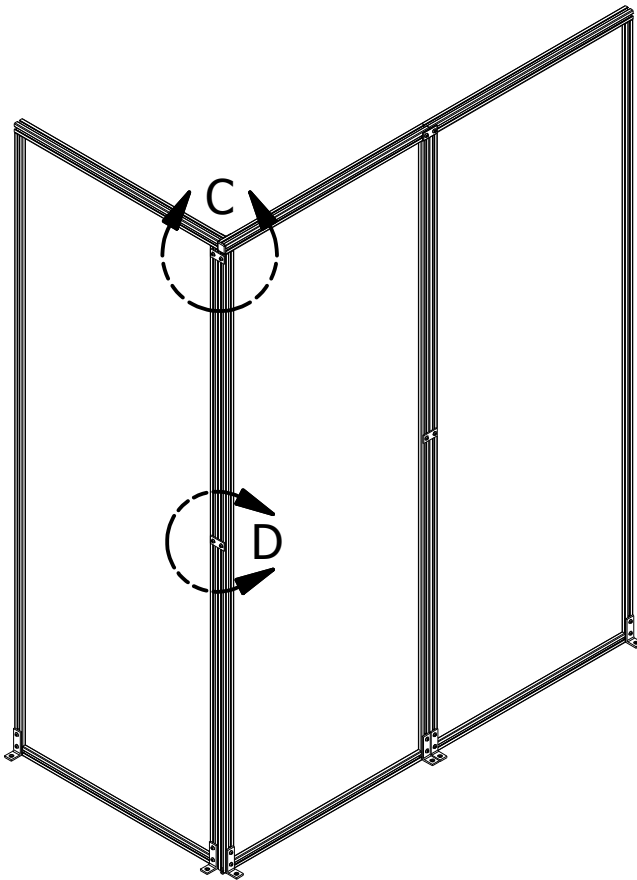

DETAIL C

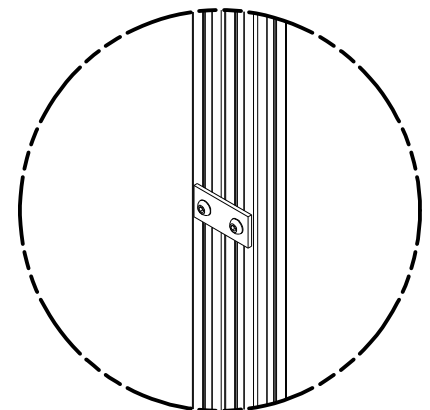

DETAIL D

Rigid Wall to Rigid Wall Application

- Ensure Rigid Walls are tight together when fastening joining strip using $\frac{5}{32}$ " T-Handle Hex wrench

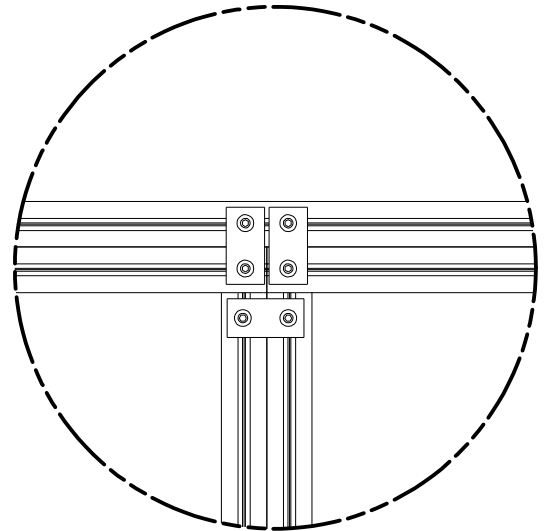
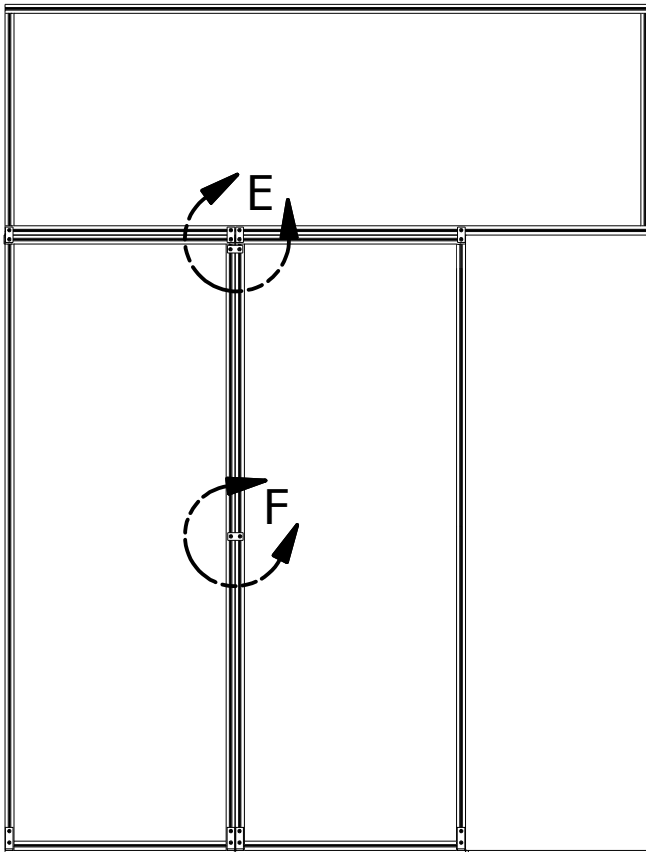

DETAIL E

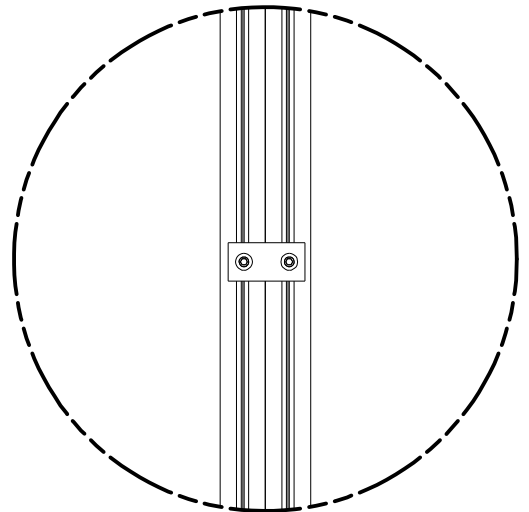

DETAIL F

Rigid Wall to Drywall Application

- Drywall Installation

--Use the Formed Mounting Bracket and secure the top and middle of the Rigid Wall to the wall using a drywall anchor or equivalent as shown in Detail G & H.

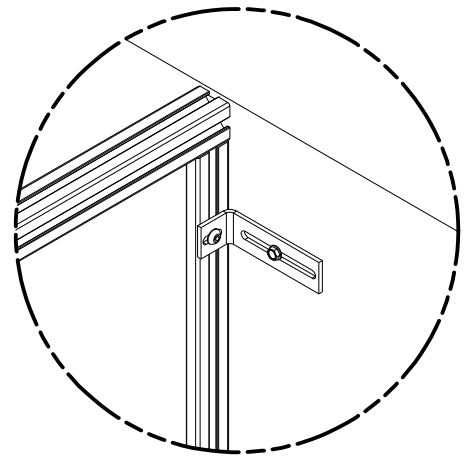
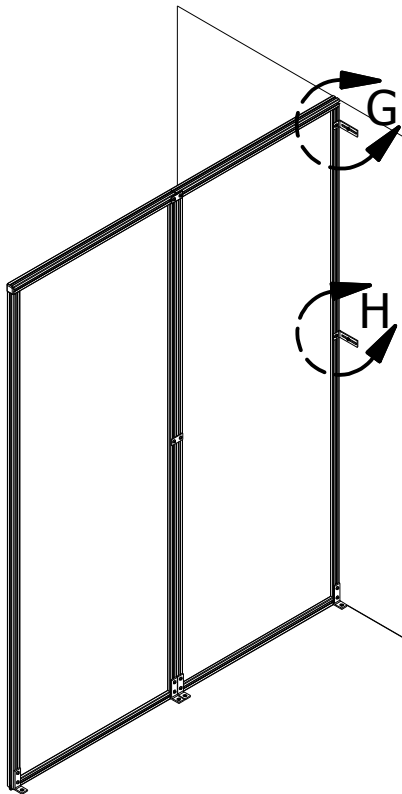

DETAIL G

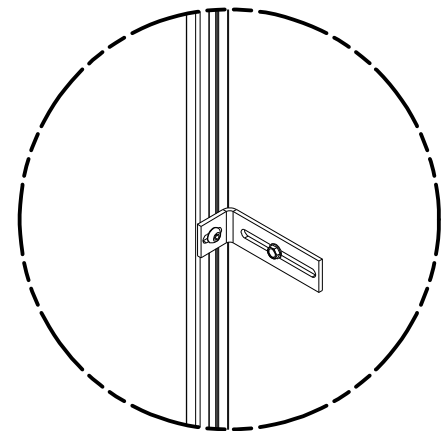

DETAIL H

Rigid Wall to Floor Installation

- With a pencil mark the center of the hole of the Floor Bracket on the floor.
- Lift the Floor Bracket up out of the way and lightly tighten so it will not fall down.
- Dependant on the floor, use a $\frac{1}{4}$ " drill bit (masonry or regular) and drill a hole into the floor.
- Place a #10-12 Blue Plastic Anchor into the hole and using a hammer lightly pound it into the hole drilled in the previous step.
- Loosen the Floor Bracket and set it on the floor in place.
- Insert the #10 x 1- $\frac{1}{2}$ " Pan Head Screw through the hole of the Floor Bracket into the Blue Plastic Anchor and secure using a Phillips drill bit.
- Using $\frac{5}{32}$ " T-Handle Hex wrench secure the Floor Bracket to the Rigid Wall.

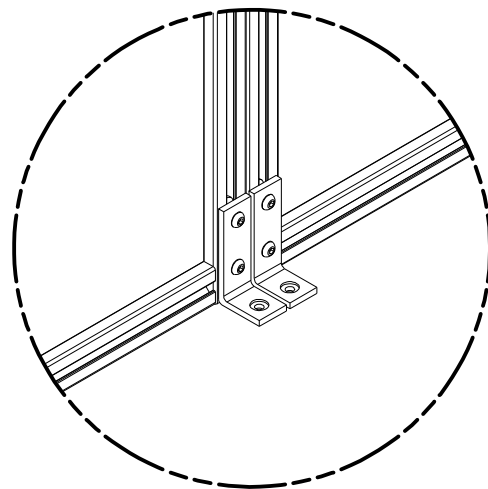
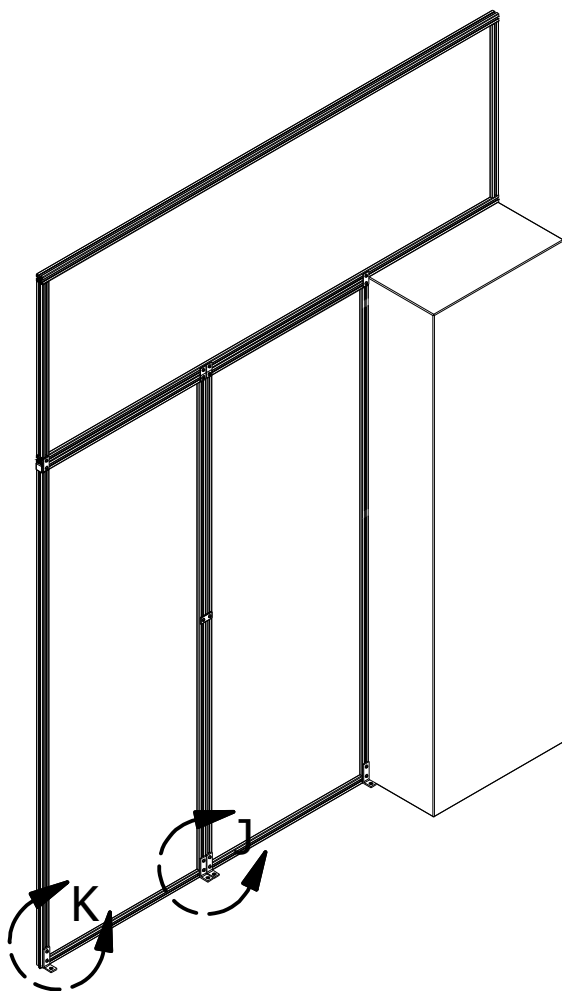

DETAIL J

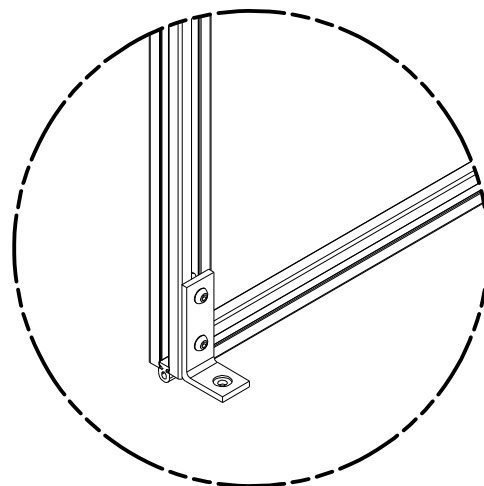

DETAIL K

End Cap Application

- Place Black End Caps on all of the the exposed ends of the aluminum extrusion for a finished look.

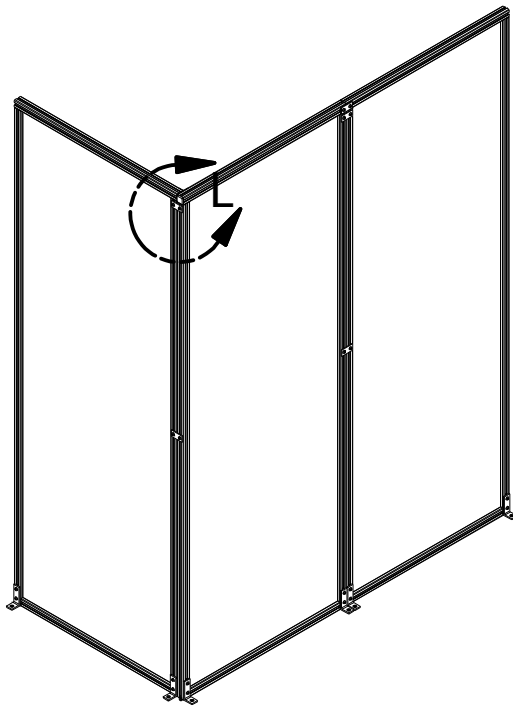

Location of End Caps

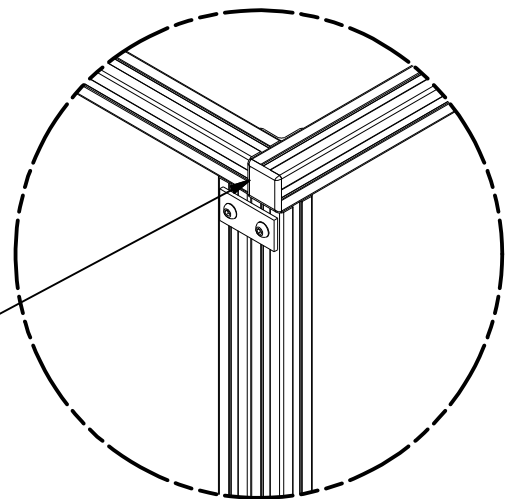

DETAIL L

Rigid Wall Maintenance

Cleaning Powder Coated, Anodized, and Polyvision CeramicSteel Finished Products:

Gordon's clear anodized and powder coated aluminum products may be kept clean and bright using the following steps:

1. For normal cleaning, a soft cloth with mild soap and water should be used. Material should have excess water wiped off.
2. If cleaning has been postponed for an extended period time and/or a tough "stain" is visible, first follow step one above. If this does not sufficiently clean the material, you should use a soft cloth with a 50-50 mixture of water and Isopropyl Alcohol. Material should have excess liquid wiped off.
3. If step one and two above is still not sufficient, you may use the 50-50 mixture of water and Isopropyl Alcohol with a small amount of "Comet" dabbed on the cloth. The damp cloth with the "Comet" should be used in a circular motion being careful not to rub to hard and leave scratches in the finish. Once done, the material must be wiped clean with a damp cloth to remove any "Comet" residue.

Cleaning twin wall polycarbonate panels:

Use a warm soapy (mild liquid dish soap) water to clean polygal sheets. Wipe with a soft, clean lint-free cloth dampened with the soapy water. Wipe panel again with a lint-free cloth dampened with water only to remove soap residue. Dry with a soft cloth.

Cleaning procedures should be initiated as soon as practical after completion of installation to remove construction soils and accumulated soils from handling.