



DG 3.0 Grid (Imperial)
Data Center Grid

Installation Instructions



PART 1 - STORAGE AND HANDLING

1. After receiving materials, transfer material immediately to a safe, dry, climate-controlled place where it will not be damaged during storage.
 - a. Do not store Gordon, Inc. product or components outdoors.
 - b. Store Crates and / or Cartons flat in a dry location away from activity.
 - c. Do not store near corrosive material such as acids, salt, fertilizer, etc.
 - d. All materials should be protected during site storage to prevent damage to the finished work from other trades.
 - e. Store materials inside a well-insulated area, away from concrete and masonry and protected from the weather, moisture, soiling, abrasion, extreme temperatures and humidity.
 - f. Protect the strippable protective covering on metal panels from exposure to sunlight, heat, and high humidity.
 - g. Store product in Gordon's unopened packaging until installation of product.
 - h. Prevent contact with material that may cause discoloration, staining, or corrosion.
 - i. Store in flat, fully supported position.
 - j. Store to prevent twisting, bending, abrasion, scratching, and denting.
 - k. Do not drop or stand containers on edges or corners.
 - l. Gordon, Inc. components and systems are not packaged to receive the load of any other material stored or stacked upon it. Therefore, **DO NOT DOUBLE STACK OR STORE OTHER MATERIAL** on top of the packages or crates.
2. Inspect all material prior to installation. Do not install any substandard or unacceptable material. Gordon, Inc. will not be responsible for the cost of repair or removal, or costs resulting from removal of rejected material, or the installation of replacement material.
3. Material should be cleaned thoroughly prior to installation.

PART 2 - INSTALLATION

DG Series Grid is usually hung from the structure above by the 3/8-16 all-threaded rod and turnbuckle assembly. Below is an installation sequence for installing the Grid. The 3/8-16 all-thread rods between the building structure or intermediate steel and manufacturer-furnished turnbuckles shall be supplied by the Contractor.

2.01 - APPLICABLE CODES AND STANDARDS FOR INSTALLATION

1. Project Specifications
2. Architect approved Shop Drawings
3. American Society for Testing and Materials (ASTM)

2.02 - SPECIAL TOOLS REQUIRED

- Channel-Lock or other adjustable-type pliers
- #3 Phillips head bit

2.03 - INSTALLATION SEQUENCE

Step 1:

Suspend the 3/8-16 threaded rods from the structure above. Be sure to check the location and length of the threaded rods before and after suspending them. Use Shop Drawings to locate the exact hanging locations. A laser or other suitable leveling tool should be used to assure a consistently level finished product.

Step 2:

Refer to the Drawings to determine if the perimeter condition will be “Fixed” or “Floating.” Fixed perimeters utilize DG-WA Wall Angle extrusions fastened to existing walls. Floating perimeters utilize Perimeter Main Tees suspended from overhead.

2A – “FIXED” Perimeter Wall Angle Installation:

Attach lengths of DG-WA Wall Angle to walls using appropriate fasteners for your type of existing wall. It is advisable to pick one wall as a starting point, and begin attaching Wall Angle from the center of the wall out toward the corners. A laser or other suitable leveling tool should be used to assure a consistently level finished product. Continue attaching Wall Angle around walls and columns, if any, until complete. Wall Angle must be tight against the wall. If a seal is required use an approved sealant. See Figure A for reference.

Step 3:

Once the perimeters are completely installed, the rest of the Grid installation can begin. Place a DG Main Tee face down on a protected surface, such as a covered table or floor. Attach the 4-Way Connectors to the 12' Main Tees. Position the center hole of the Connector exactly 12" from the end of the Main Tee for 24" modules or 12 ¼" from the end for 24 ½" modules. Then install 4-Way Connectors 24" or 24 ½" O.C. as required for the job. Insert two (2) of the factory-supplied bolts into the two (2) holes closest to the center of the Connector. Hand start these bolts and tighten to 30-35 inch pounds (¼ turn past hand tightening). Install all Connectors onto the Main Tee the same way. Screw a 3/8" nut 1/2" up onto the right-hand end of the RH/LH 9" Starter Rod and insert into the threaded center hole of the Connectors at a maximum of 48" or 48 ½" O.C., as required. Use vise grip pliers clamped onto the non-threaded shank of the Starter Rod. The Rod should be nearly “bottomed-out” into the screw slot of the Tee. Screw the Turnbuckle onto the top of this Rod. Make sure that the Rod is 2/3rd inside the Turnbuckle. Repeat until all Starter Rods and Turnbuckles are installed. Remember: Rod suspension is only on 48" x 48" or 48-1/2" x 48-1/2" centers, not at every intersection. Repeat the same step for all the standard length (12') Main Tees.

Step 4:

Next, insert the Cross Tees into the 4-Way Connectors between two (2) Main Tees and fasten them using the 1/4 -20" bolts, thus creating a 4' x 12' "ladder assembly." Repeat Steps 3 and 4 to make similar ladder assemblies.

Step 5:

Now, hoist the ladder assembly into place and then attach the Turnbuckle to the suspended all threaded rods. Adjust the suspension height using the Turnbuckle as required. Similarly, suspend all the ladder assemblies in place.

Step 6:

Main Tees are spliced together with the Main Tee Splice Connector. When splicing the Main Tees, hold the Main Tees tightly against each other and then use the Splice Connector with the 1/4-20 bolts to attach them. Make sure that there is no gap between the Main Tees and that the Main Tees are perfectly aligned.

Additional Main Tees may now be installed in the same manner using a 4' Cross Tee as a spacer.

Step 7:

After all the standard assemblies are installed, field cut the Cross Tees to fit between the Wall Angle/Perimeter Tee and the first run of Main Tees. Install the Cross Tee by inserting the Cross Tee into the 3-Way Connector at the perimeter and the 4-Way Connector at the Main Tee and securing them using the 1/4"-20 bolts. Repeat until all Cross Tees are in place.

Step 8:

Check the entire Ceiling Grid System once all the Tees have been installed and level to within 0.10" overall or to 0.06" in any 10' length. Minor adjustments can be done by adjusting the Turnbuckles. You may now proceed to module installations and laying in the blank Panel tiles.

2.04 - MODULE INSTALLATION

Once the Grid is installed, the module installation can begin. If lay-in lamp modules are to be used, they should be installed first. This is to make wiring easier. Once the light fixtures are in place and wired, the cable trays or other utilities or equipment may be suspended from the 3/8-16 screw slot thread boss in the face of the Grid members. This is accomplished by screwing the connection fasteners directly into the screw slot using a washer and 3/8-16 hex nut to lock the suspension fastener securely in place.

2.05 - CEILING BLANK TILES

After all of the lighting and utility racks are in place, the blank Panels are installed. Properly sized Panels are placed into the Grid openings where shown in the project drawings. If required, optional blank Panel Hold Down Clips are secured to the thread boss in the top of the Grid extrusions utilizing 1/4-20 x 3/8 bolts, furnished by Gordon, Inc.

2.06 - GASKET SEAL (OPTIONAL)

If required for the job, Gordon, Inc. provides gasket tapes, shipped loose on all Grid members. After Grid members are bolted together, carefully peel off the backing strip and press firmly in place to affix the adhesive bottom of the gasket securely to the Grid flange.

Properly installed, the die cut end of the Cross-Tee gasket will compress against the side of the Main Tee gasket to affect an air-tight seal under compression.

2.07 - MAINTENANCE

When suspending loads from the DG Grid, the Installer should take care not to over-tighten bolts. First, tighten bolts by hand and then use a wrench to tighten 1/8 to 1/4 turn. If using a lock washer, it should only be tightened to the point of compressing the lock washer.

PART 3 - ILLUSTRATIONS

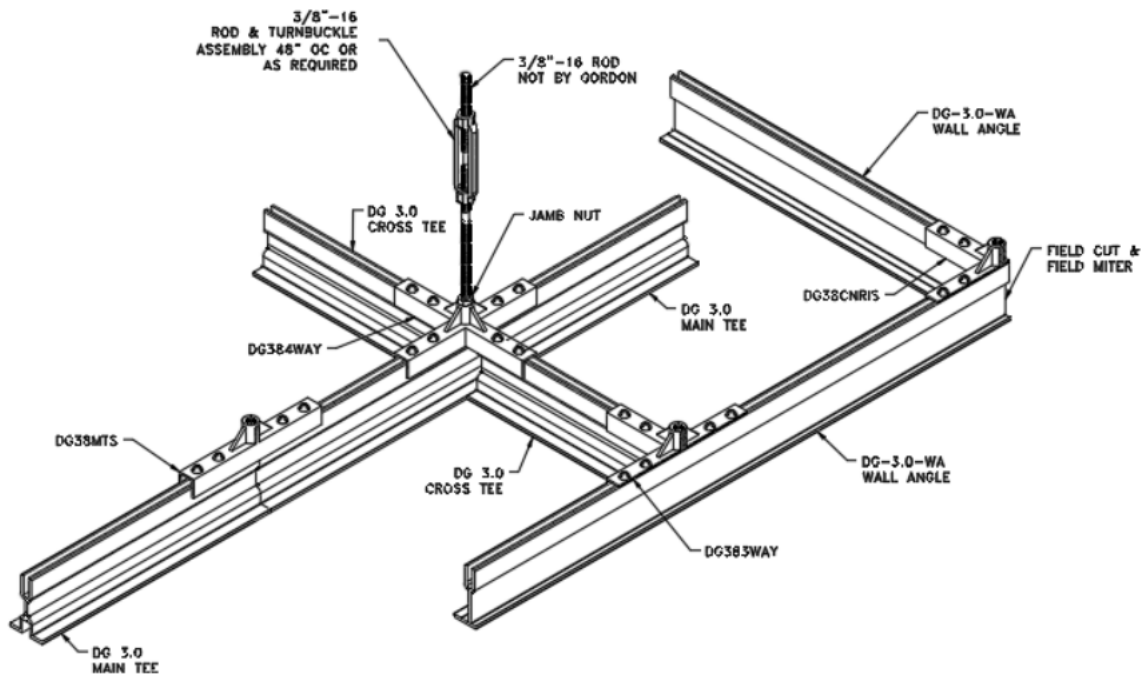

Figure A: DG Series Grid with Fixed Perimeter Condition

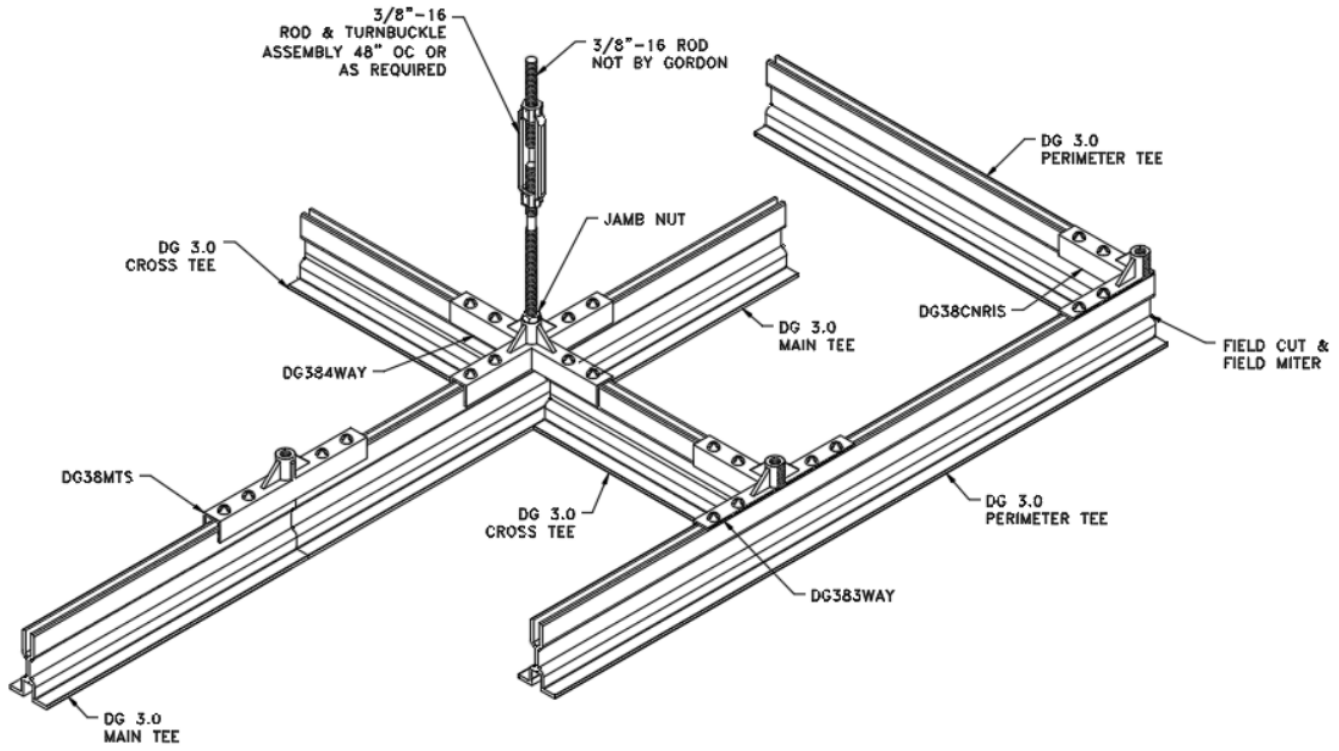

Figure B: *DG Series Grid with Floating Perimeter Condition*



GORDON[®]
ARCHITECTURAL+ENGINEERED SOLUTIONS

5023 HAZEL JONES ROAD
BOSSIER CITY, LA 71111
800-747-8954

WWW.GORDON-INC.COM
SALES@GORDON-INC.COM

