

CAULK ALL EDGES AT WINDOW / MULLION & PARTITION WALL

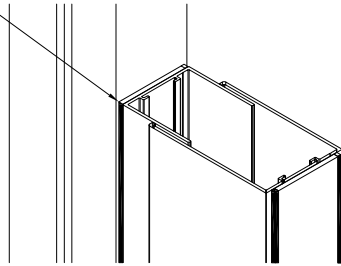

MULLION MATE® (SERIES 40)  
VARIES IN VERTICAL HEIGHT  
30" MIN TO 192" TYPICAL

NOTE: STACKING PIECES MAY  
BE SPLICED TOGETHER WHEN  
GREATER THAN 192" IS  
REQUIRED.

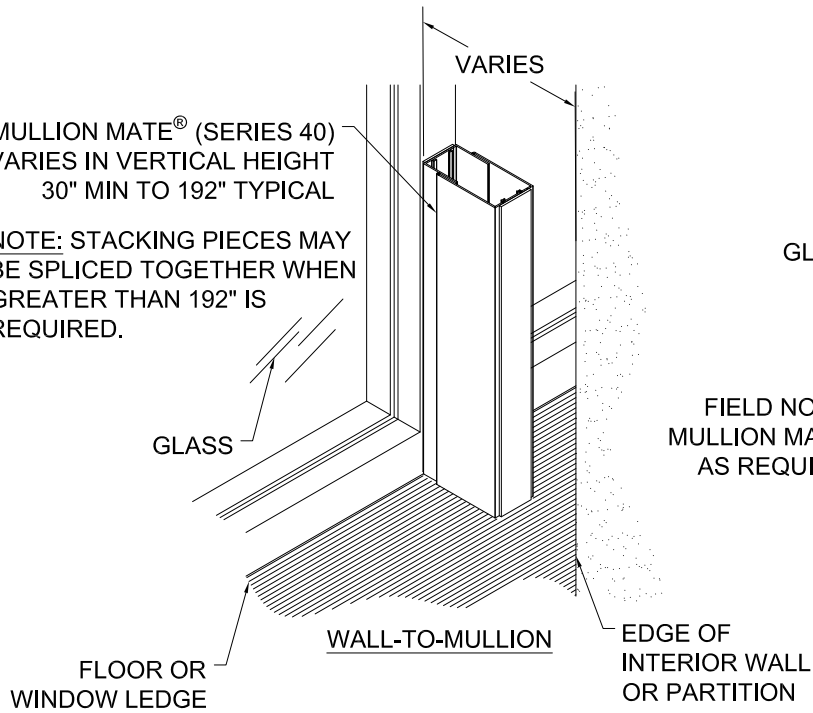

GLASS

FIELD NOTCH  
MULLION MATE®  
AS REQUIRED

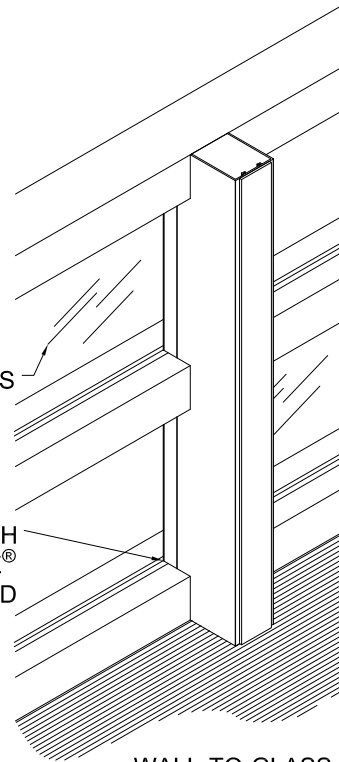

WALL-TO-GLASS  
(FIELD NOTCH)

NOTE: FACTORY NOTCHING IS  
AVAILABLE, CONTACT FACTORY.

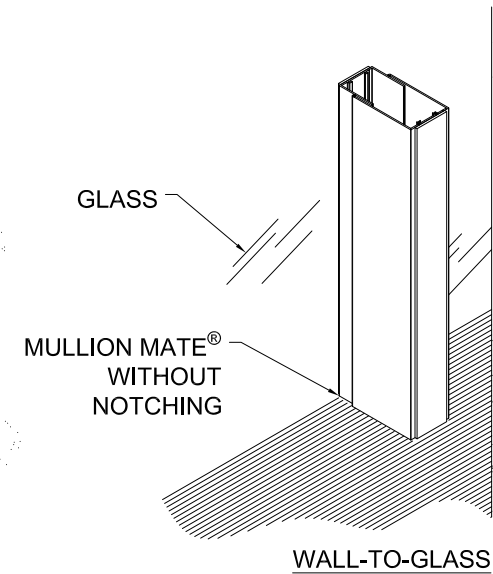

**GORDON**®  
ARCHITECTURAL+ENGINEERED SOLUTIONS

5023 Hazel Jones Rd.  
Bossier City, LA 71111  
800.747.8954  
GORDON-INC.COM  
sales@gordon-inc.com

PARTITION GAP CLOSURES  
MULLION MATE - SERIES 40  
APPLICATION ISO VIEW

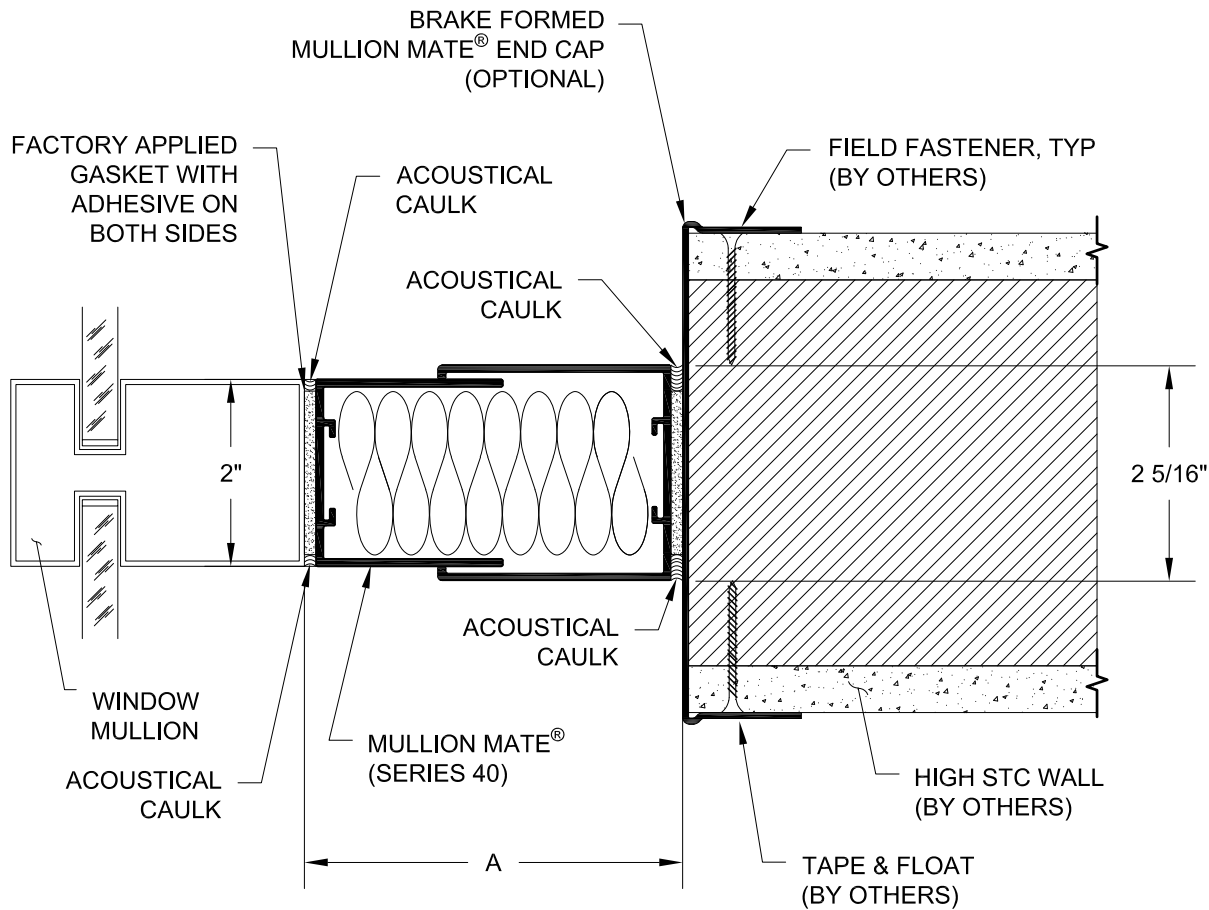

MULLION MATE® SIZING	
PRODUCT	DIM "A"
MM3	3" TO 3-15/16"
MM4	4" TO 4-15/16"
MM5	5" TO 6-15/16"

**WALL-TO-GLASS APPLICATION**  
 \*MULLION MATE® CAN BE INSTALLED AGAINST MINIMUM 1/8" THICK GLASS. INSTALL THE GASKET AGAINST THE GLASS SIDE FIRST. CARE SHOULD BE GIVEN TO PROPERLY POSITION GASKET PRIOR TO CONTACTING GLASS.

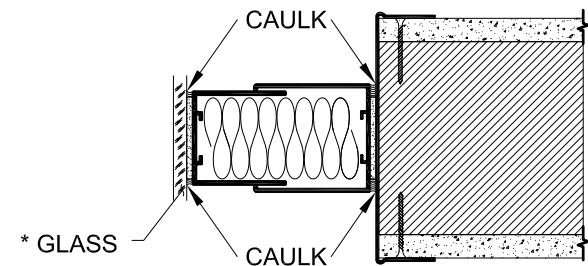

NOTE: FIELD CAULKING REQUIRED. A PAINTABLE, ACOUSTICAL CAULK IS SUPPLIED WITH EACH ORDER TO SEAL EDGES FOR A HIGHER STC RATING.

**GORDON**®  
 ARCHITECTURAL+ENGINEERED SOLUTIONS

5023 Hazel Jones Rd.  
 Bossier City, LA 71111  
 800.747.8954  
 GORDON-INC.COM  
 sales@gordon-inc.com

**PARTITION GAP CLOSURE  
 MULLION MATE - SERIES 40  
 MM3, 4, & 5 SECTION**

NOTE: FIELD CAULKING REQUIRED. A PAINTABLE, ACOUSTICAL CAULK IS SUPPLIED WITH EACH ORDER TO SEAL EDGES FOR A HIGHER STC RATING.

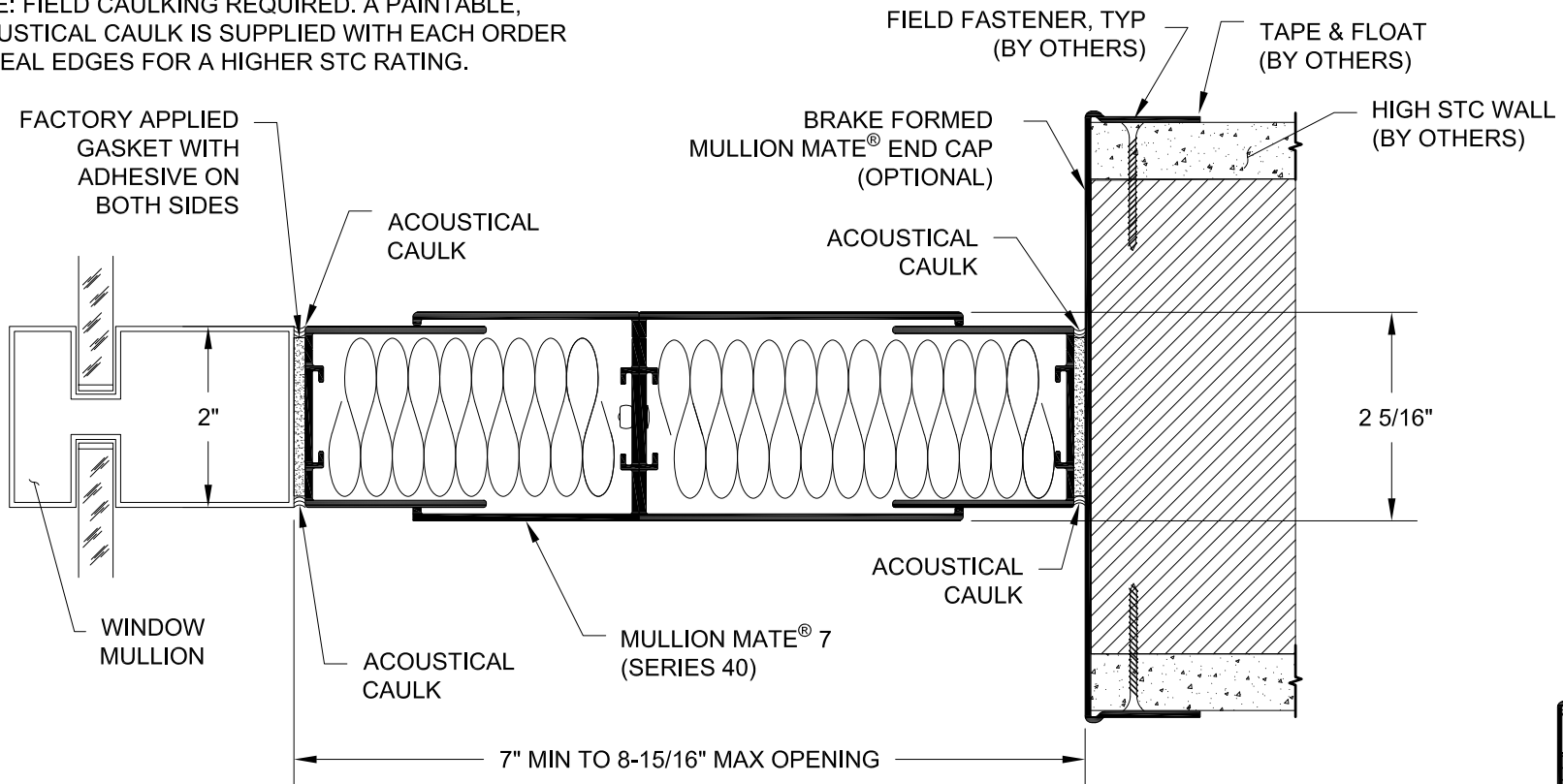

**WALL-TO-GLASS APPLICATION**  
 \*MULLION MATE® CAN BE INSTALLED AGAINST MINIMUM 1/8" THICK GLASS. INSTALL THE GASKET AGAINST THE GLASS SIDE FIRST. CARE SHOULD BE GIVEN TO PROPERLY POSITION GASKET PRIOR TO CONTACTING GLASS.

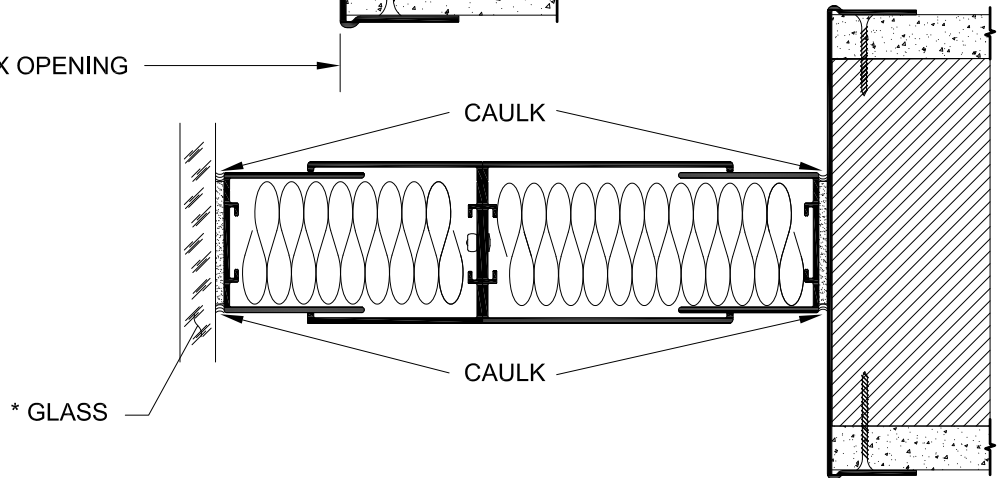

NOTE: FIELD CAULKING REQUIRED. A PAINTABLE, ACOUSTICAL CAULK IS SUPPLIED WITH EACH ORDER TO SEAL EDGES FOR A HIGHER STC RATING.

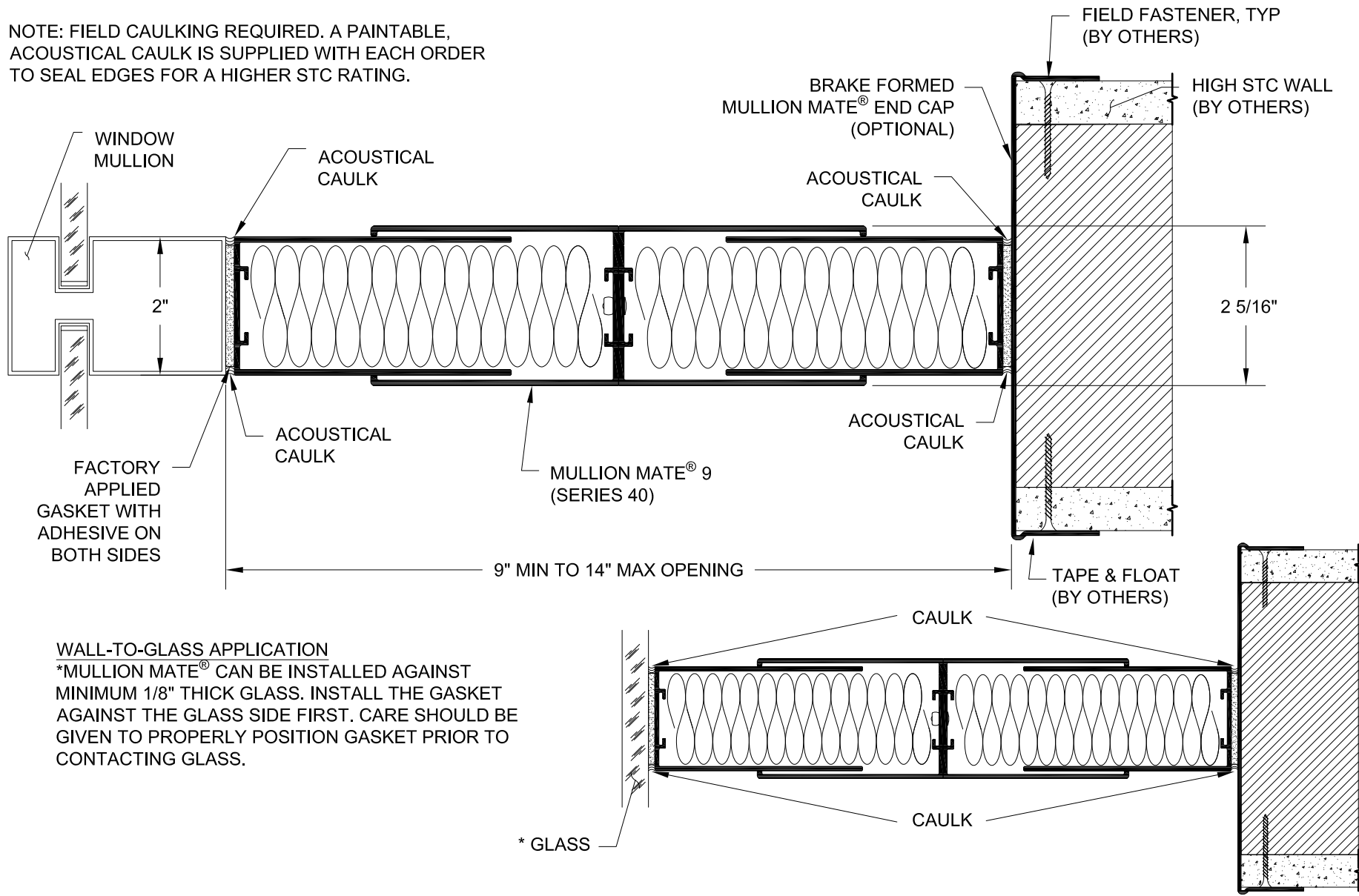

**WALL-TO-GLASS APPLICATION**  
 \*MULLION MATE® CAN BE INSTALLED AGAINST MINIMUM 1/8" THICK GLASS. INSTALL THE GASKET AGAINST THE GLASS SIDE FIRST. CARE SHOULD BE GIVEN TO PROPERLY POSITION GASKET PRIOR TO CONTACTING GLASS.

\* GLASS

**GORDON**® ARCHITECTURAL+ENGINEERED SOLUTIONS  
 5023 Hazel Jones Rd.  
 Bossier City, LA 71111  
 800.747.8954  
 GORDON-INC.COM  
 sales@gordon-inc.com

**PARTITION GAP CLOSURE  
 MULLION MATE - SERIES 40  
 MM9 SECTION**

EXTRUDED MULLION MATE <sup>®</sup> END CAPS	
PART #	"A"
MMEC-375	3-3/4"
MMEC-487	4-7/8"
MMEC-600	6"
MMEC-725	7-1/4"

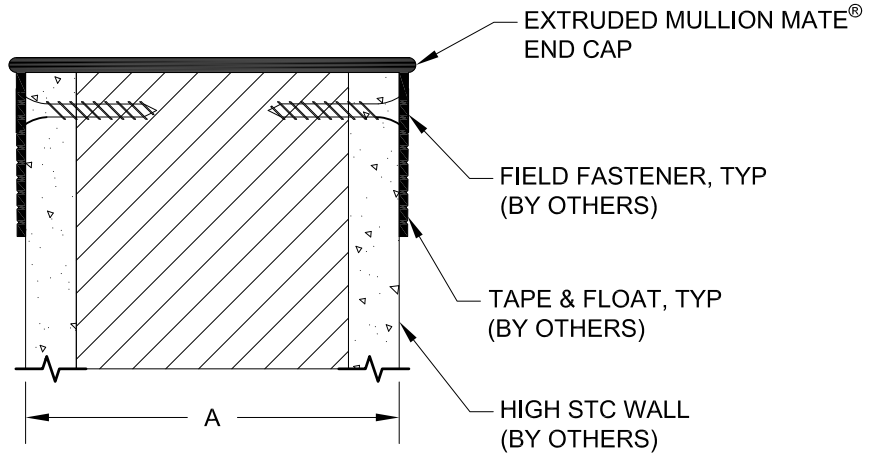

BRAKE FORMED MULLION MATE <sup>®</sup> END CAPS	
PART #	"A"
MMECBF-518	5-1/8"
MMECBF-514	5-1/4"
MMECBF-512	5-1/2"
MMECBF-618	6-1/8"
MMECBF-812	8-1/2"

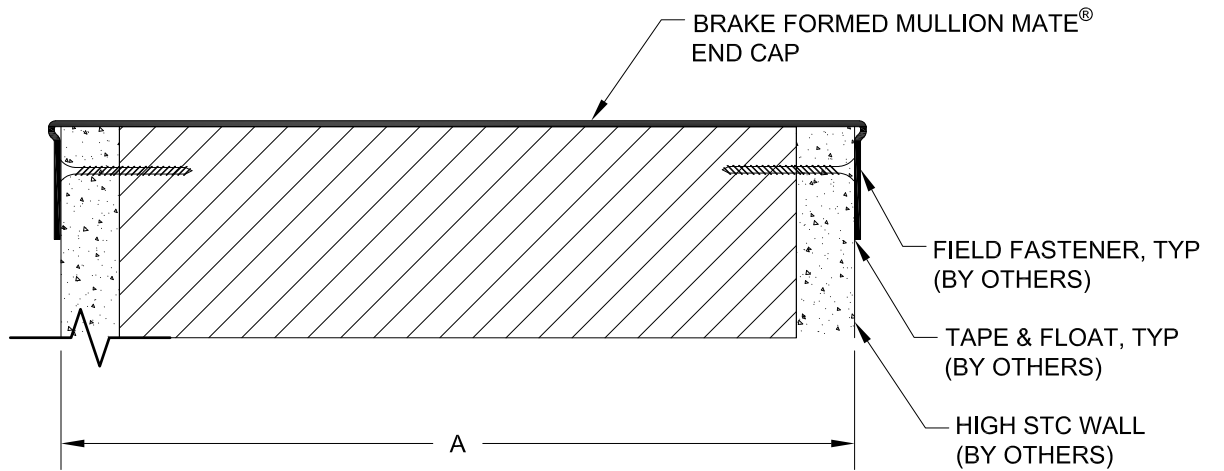

NOTE: BRAKE FORMED END CAPS CAN BE SIZED TO FIT YOUR WALL. PLEASE PROVIDE WALL THICKNESS TO FACTORY.

**GORDON**<sup>®</sup>  
ARCHITECTURAL+ENGINEERED SOLUTIONS

5023 Hazel Jones Rd.  
Bossier City, LA 71111  
800.747.8954  
GORDON-INC.COM  
sales@gordon-inc.com

PARTITION GAP CLOSURES  
MULLION MATE - SERIES 40  
END CAP SECTION