

GORDON[®]
ARCHITECTURAL+ENGINEERED SOLUTIONS

5023 Hazel Jones Rd.
Bossier City, LA 71111
800.747.8954
GORDON-INC.COM
sales@gordon-inc.com

TITLE

GORDON SECURITY WALL
FRONT ELEVATION

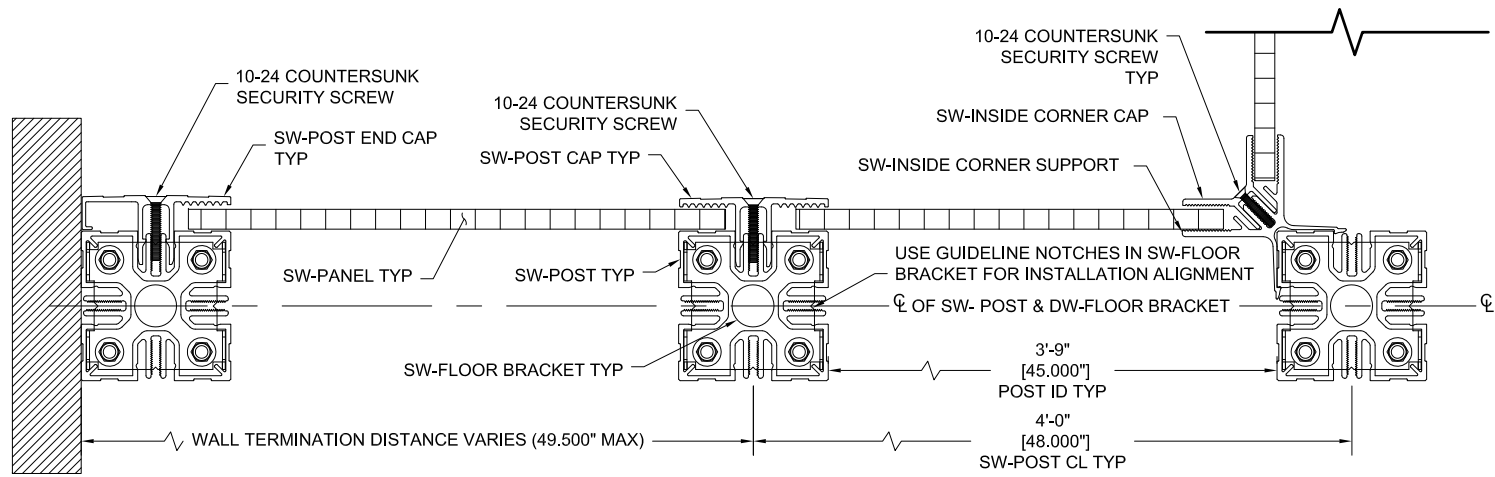

PLAN VIEW AT FLOOR

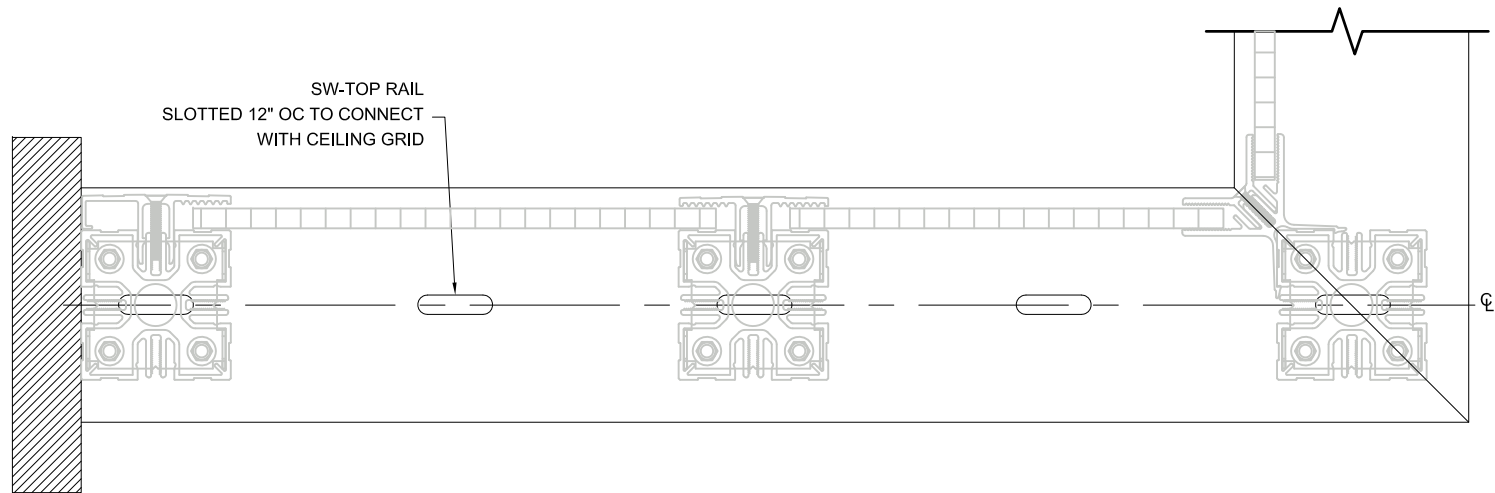

PLAN VIEW AT CEILING

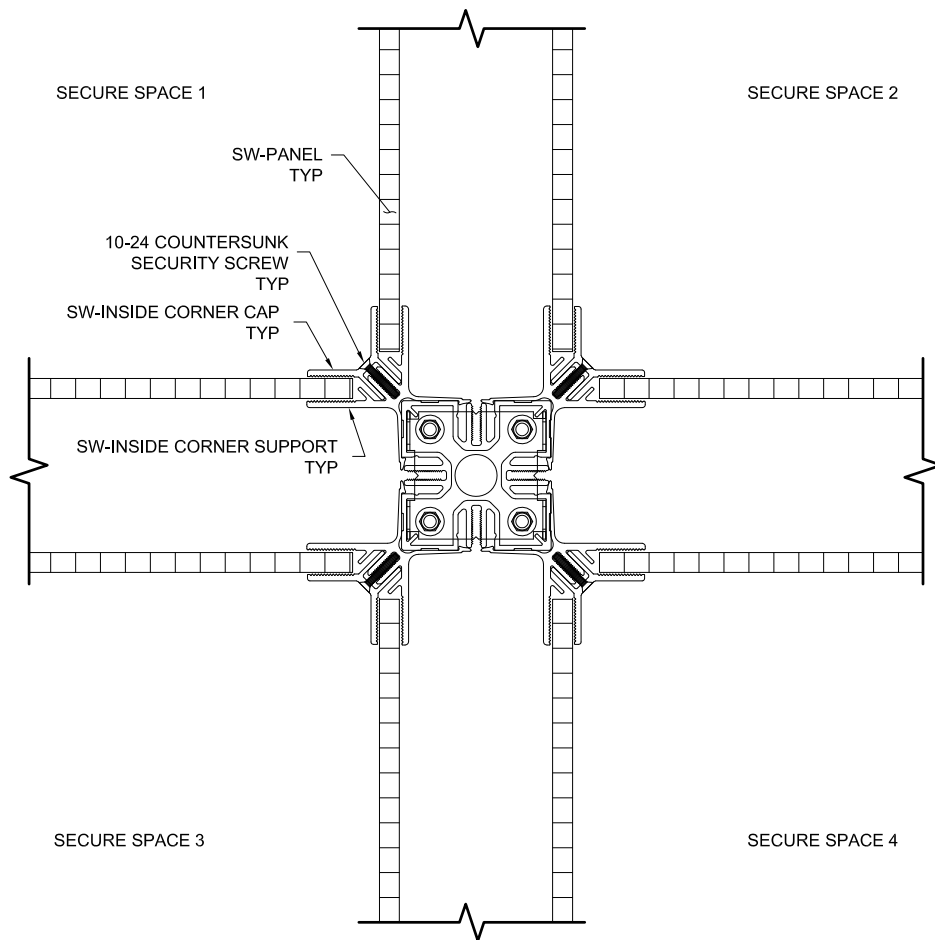

EXPANSION OPTION 1

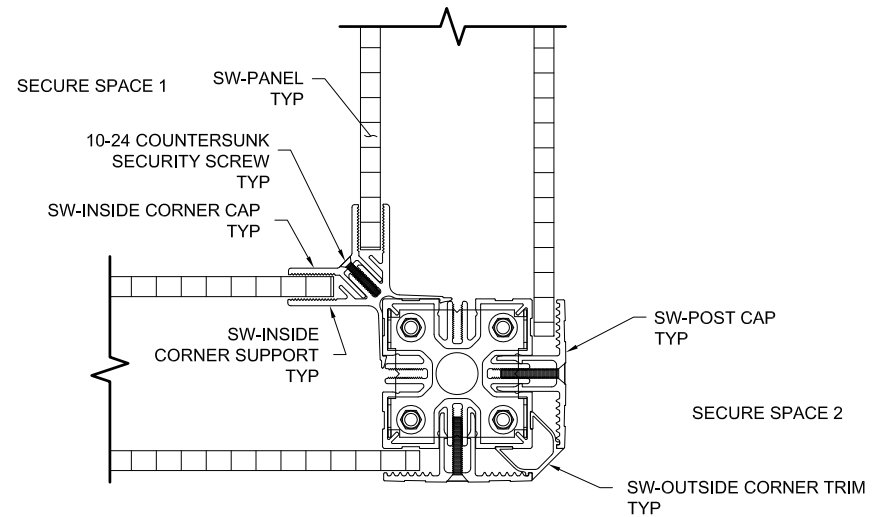

EXPANSION OPTION 2

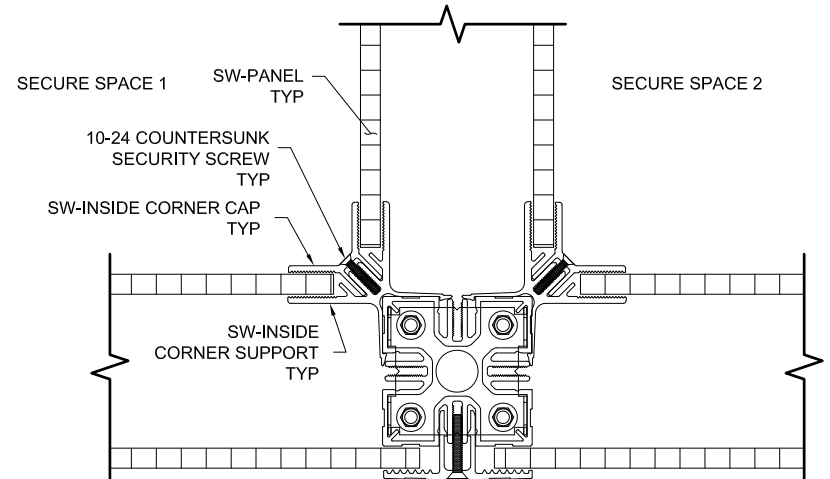

EXPANSION OPTION 3

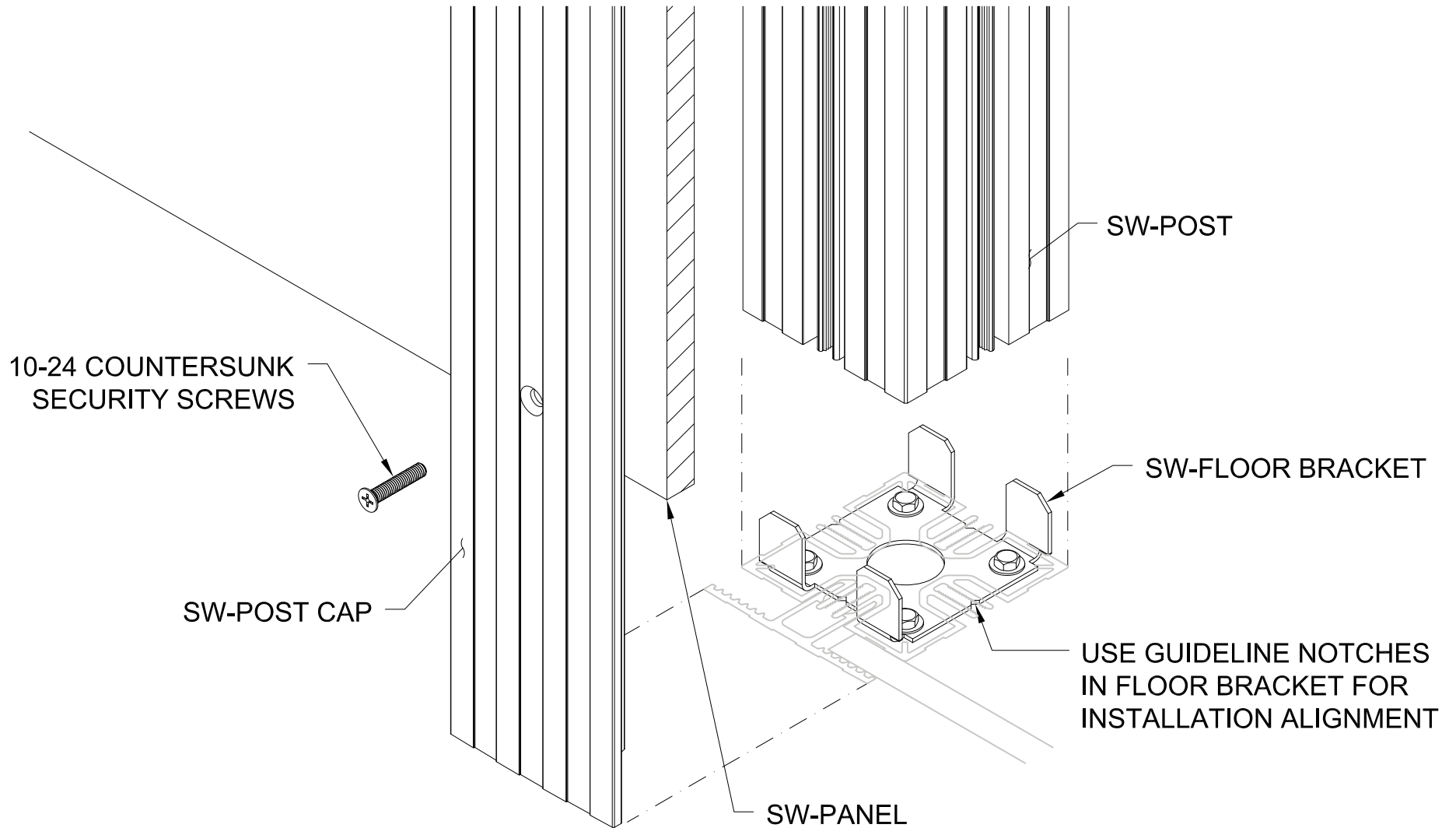

GORDON[®]
ARCHITECTURAL+ENGINEERED SOLUTIONS

5023 Hazel Jones Rd.
Bossier City, LA 71111
800.747.8954
GORDON-INC.COM
sales@gordon-inc.com

TITLE

**GORDON SECURITY WALL
ISOMETRIC AT FLOOR**

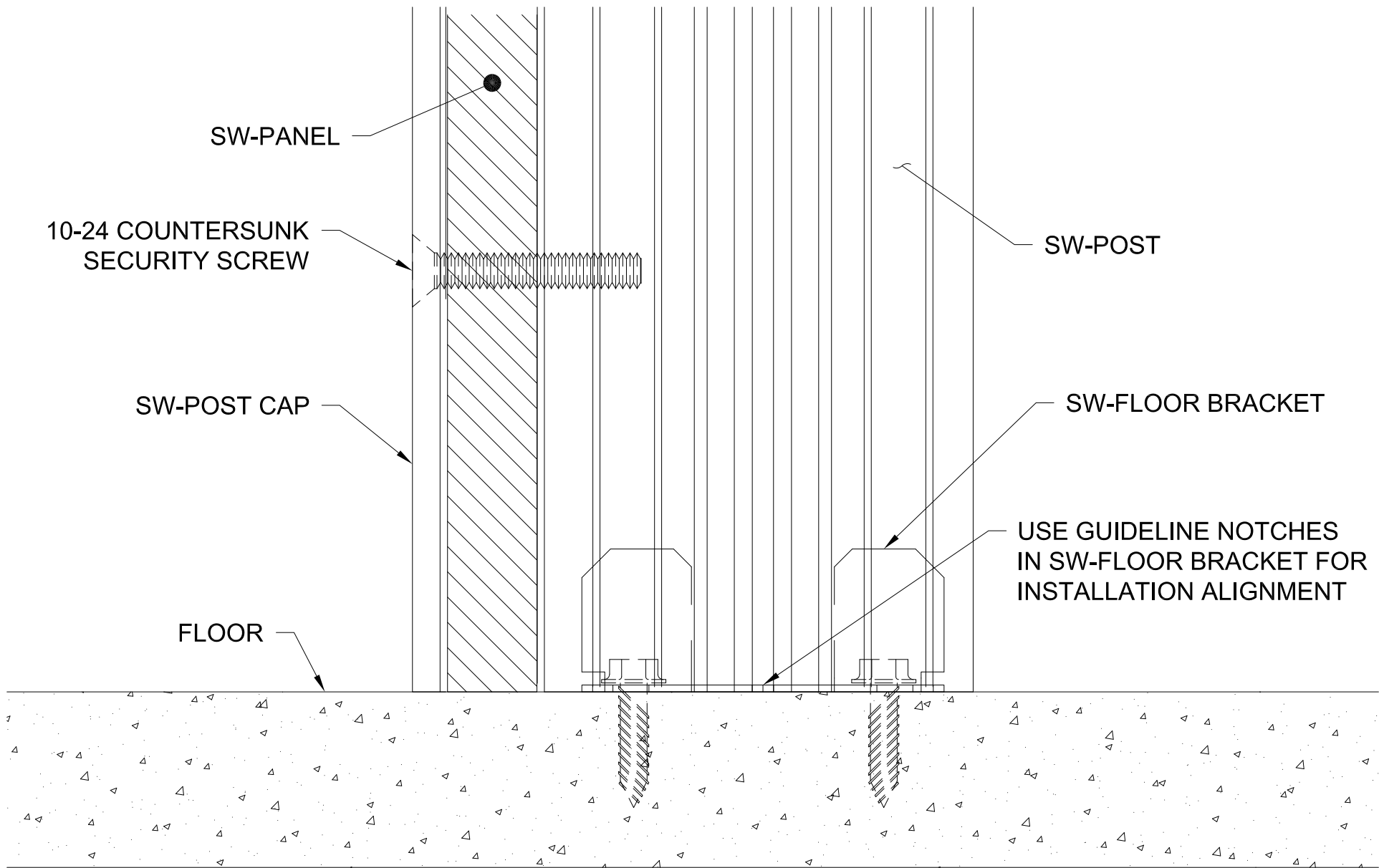

GORDON[®]
ARCHITECTURAL+ENGINEERED SOLUTIONS

5023 Hazel Jones Rd.
Bossier City, LA 71111
800.747.8954
GORDON-INC.COM
sales@gordon-inc.com

TITLE

GORDON SECURITY WALL
SECTION AT FLOOR

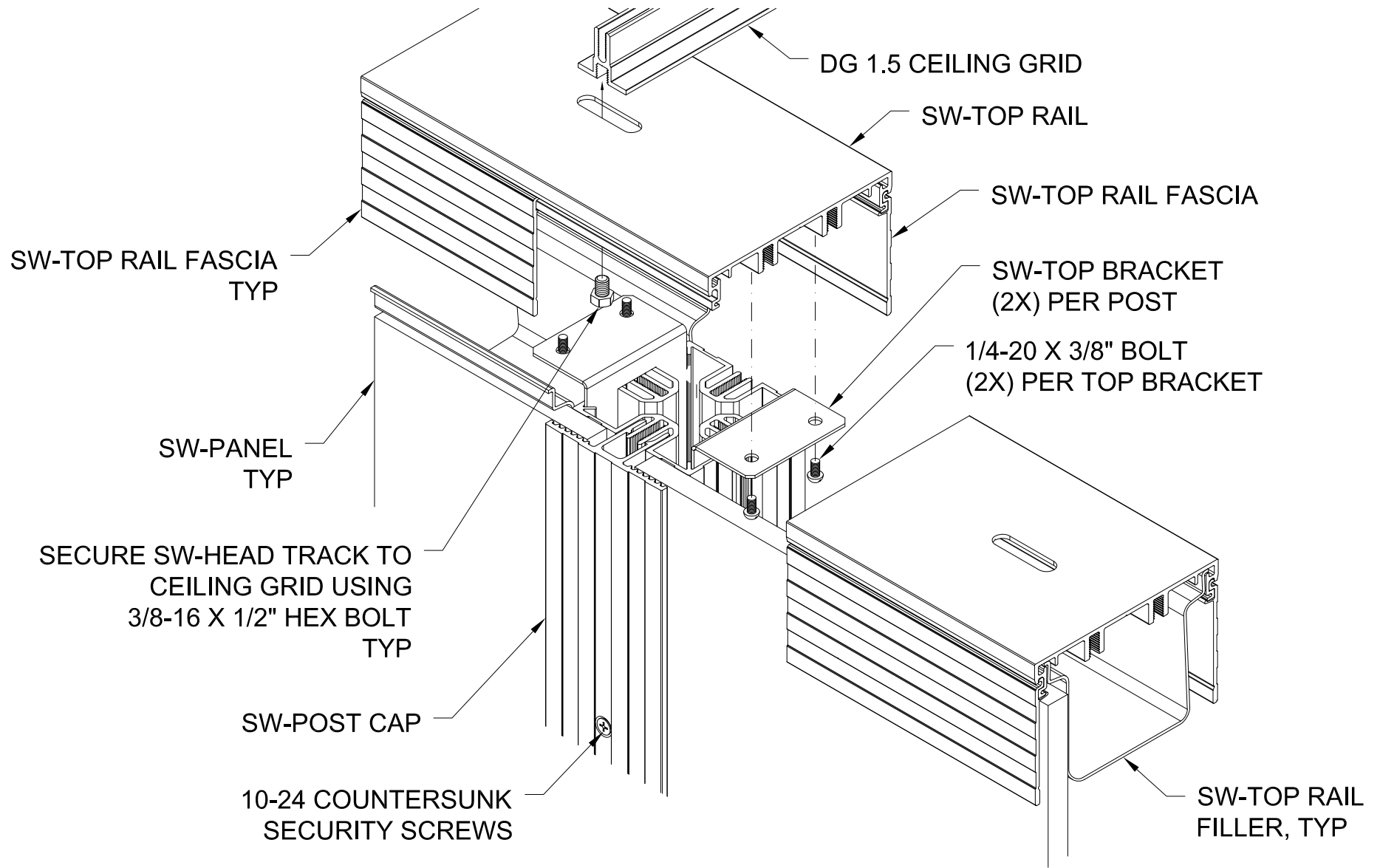

GORDON[®]
 ARCHITECTURAL+ENGINEERED SOLUTIONS

5023 Hazel Jones Rd.
 Bossier City, LA 71111
 800.747.8954
 GORDON-INC.COM
 sales@gordon-inc.com

TITLE

**GORDON SECURITY WALL
 ISOMETRIC AT CEILING**

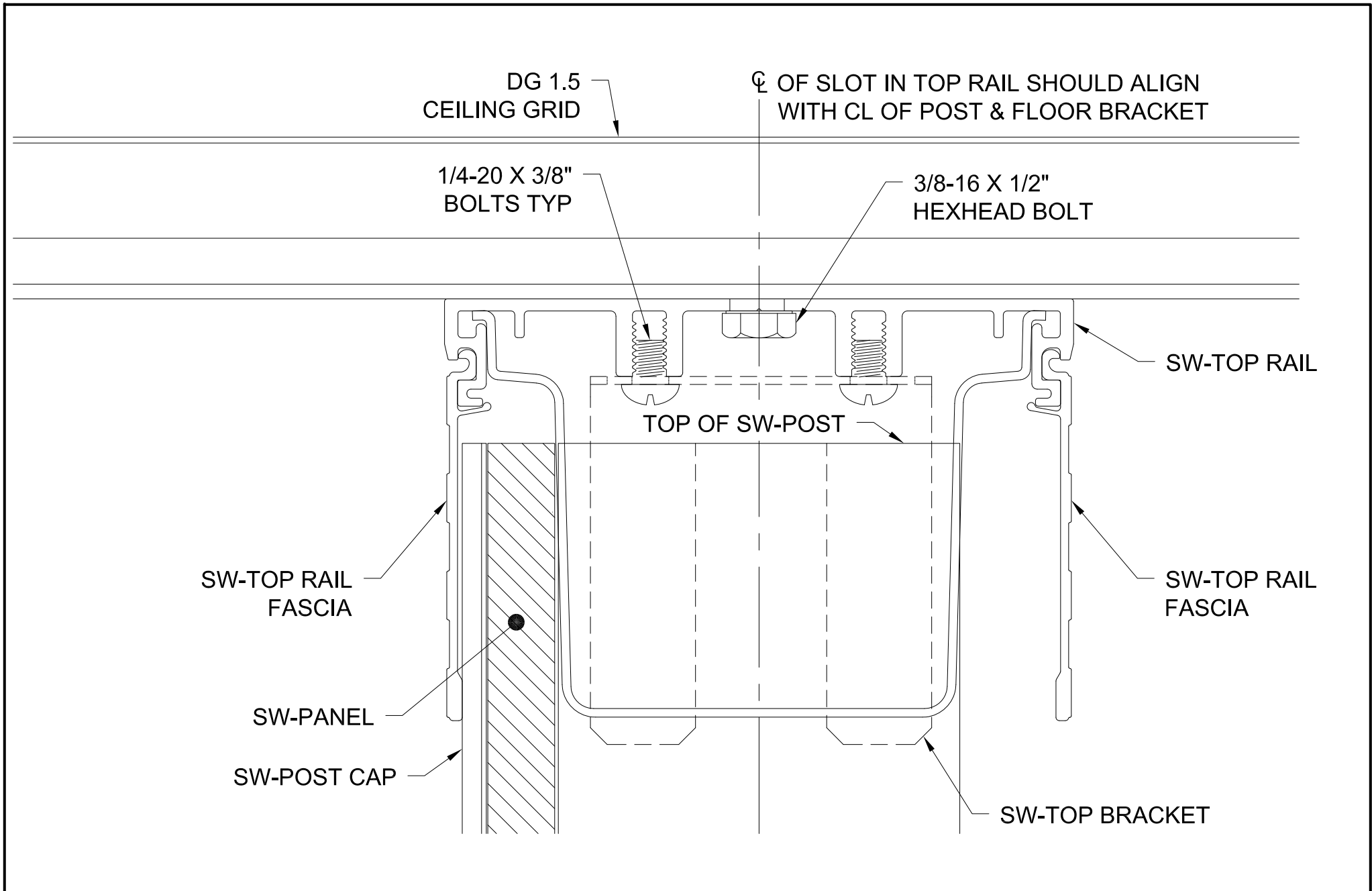

GORDON[®]
ARCHITECTURAL+ENGINEERED SOLUTIONS

5023 Hazel Jones Rd.
Bossier City, LA 71111
800.747.8954
GORDON-INC.COM
sales@gordon-inc.com

TITLE

GORDON SECURITY WALL
SECTION AT CEILING