

GENERAL SPECIFICATIONS

1. PRE-FILTER FRAME: TOP HOUSING AND SIDES ARE FABRICATED FROM GALVANIZED STEEL.
2. MOTOR / BLOWER: 1/3 HP ECM TRI-VOLTAGE MOTOR; CAN BE WIRED FOR 115/240/277 VAC / 10" FORWARD CURVE CENTRIFUGAL BLOWER
3. FILTER: HEPA, 2" MEDIA PACK WITH 3" ANODIZED ALUMINUM FRAME
4. PRE-FILTER: MERV 4 FIBERGLASS, NOMINAL 20" X 20" X 1"
5. FAN SPEED CONTROL: VARIABLE SPEED CONTROL / DIGITAL READOUT - RPM / FLOW INDEX
6. LINE CONNECTION: PER NEC CODE
7. FACE SCREEN: ANODIZED ALUMINUM, 1/8" HOLES ON 1/4" STG CENTERS, TO PROVIDE AIR FLOW UNIFORMITY AND PROTECT FILTER MEDIA.
8. HANGING PROVISION: 1/4-20 THREADS PROVIDED IN TOP (4) CORNERS FOR SUSPENSION WITH THREADED ROD OR EYE BOLTS WITH CHAIN.
9. EACH MODULE IS FACTORY TESTED AND PROVIDED WITH A QUALITY CHECK FORM.
10. EACH MODULE IS INDIVIDUALLY CARTONED FOR PROTECTION DURING SHIPPING.

OPTIONS

HOUSING FINISH:

- MILL (STANDARD)
- POWDER COATED

MOTOR CONTROL:

- MODBUS PROTOCOL CARD (INSTEAD OF VSC)

HEPA FILTER:

- 99.99% EFF @ .3 MICRONS
- 99.9995% EFF ULPA @ .12 MICRONS
- KNIFE EDGE (FOR USE W/GEL GRID CEILINGS)
- PTFE FILTER MEDIA

ACCESSORIES:

- A/C DUCT COLLAR

SPECIAL DIMENSIONS:

- 23" X 23" (FOR USE IN ROD-SUSPENDED CLEANROOM CEILINGS 2'0" X 2'0" O.C.)

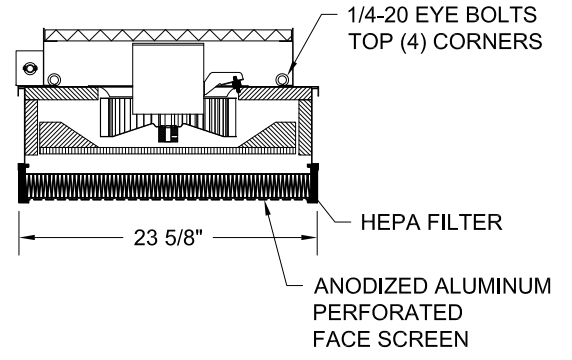
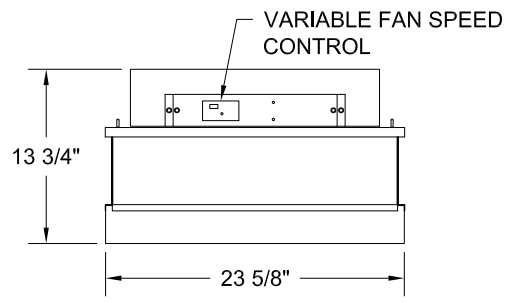
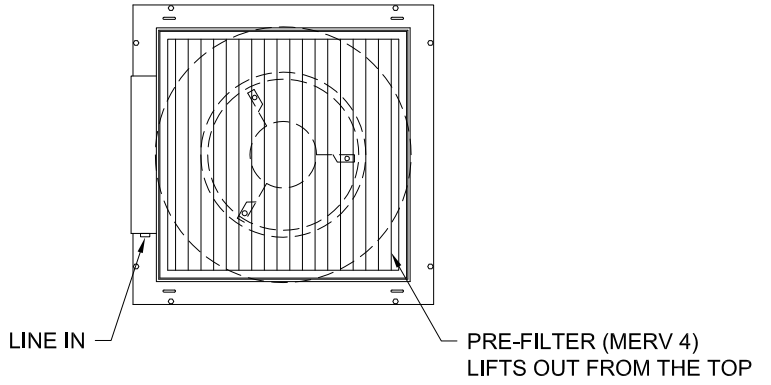

THE DESIGN AND CONCEPTS REPRESENTED BY THIS PRINT AND ACCOMPANYING DOCUMENTS ARE THE SOLE PROPERTY OF GORDON, INC. AND MAY NOT BE USED, COPIED, OR REPRODUCED WITHOUT PRIOR WRITTEN CONSENT OF SAID OFFICE.



5023 Hazel Jones Rd.
Bossier City, LA 71111
800.747.8954
GORDON4INC.COM
sales@gordon-inc.com

SALES CODE
SALES DIE #
ARCHITECT

SHEET TITLE
2X2 ECM PHANTOM
JOB NAME

RUNS: QUANTITY:
SHEET 1 OF 1
SALES ORDER
PATH & DRAWING NUMBER
G:\IT\WEBSITE GRAPHICS\CHECKED IN
ECM-PHANTOM-2X2

CUSTOMER
COMP DATE 08/07/19
DRAWN BY DS
APRVD BY CE
REL DATE 08/09/19
DRAWING SCALE AS NOTED
PLOTTED SCALE 1:1
SOFTWARE USED AutoCAD
REVISION -