

-   
 PATTERN  
"A"
-   
 PATTERN  
"B"
-   
 PATTERN  
"C"
-   
 PATTERN  
"D"
-   
 PATTERN  
"E"
-   
 PATTERN  
"F"
-   
 PATTERN  
"J"

**GORDON**® ARCHITECTURAL+ENGINEERED SOLUTIONS

5023 Hazel Jones Rd.  
Bossier City, LA 71111  
800.747.8954  
GORDON-INC.COM  
sales@gordon-inc.com

**WALLS / CLADDINGS  
CORRUGATED - PANELS - VERTICAL  
ISOMETRIC VIEW**

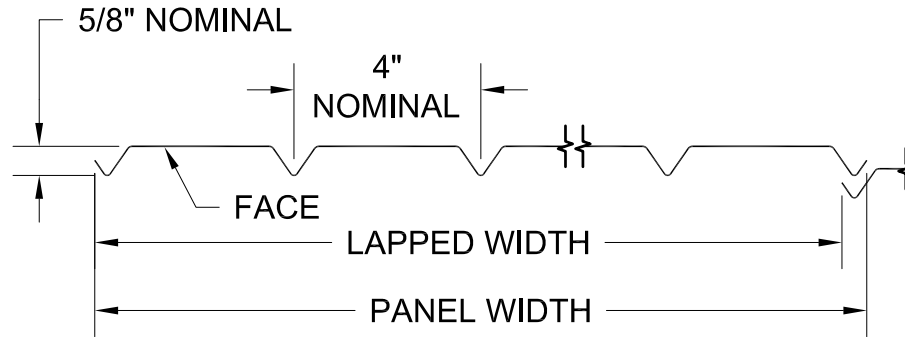

**AO - ALUMINUM / STEEL**  
 MAXIMUM LENGTH: 120"

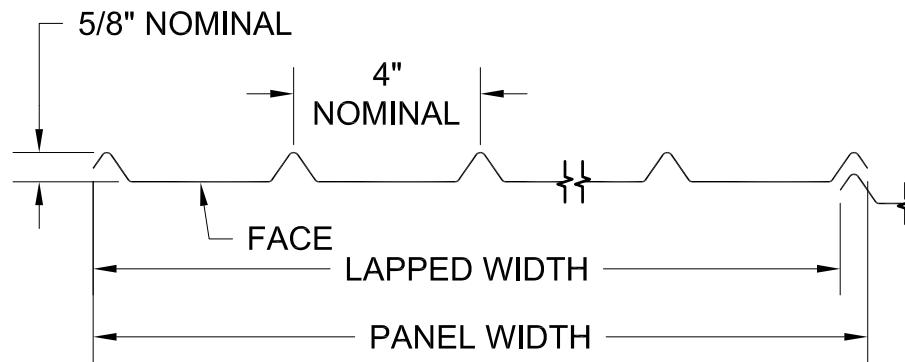

**AI - ALUMINUM / STEEL**  
 MAXIMUM LENGTH: 120"

NOMINAL DIMENSIONS	
LAPPED WIDTH	PANEL WIDTH
40 3/4"	41 1/2"
51 1/4"	52"

AVAILABLE MATERIAL	
ALUMINUM	STEEL
.032"	24 GAUGE
	26 GAUGE

NOTE: ALL DIMENSIONS ARE NOMINAL AND WILL VARY WITH DIFFERENT THICKNESSES AND TYPES OF MATERIAL.

STANDARD FACTORY TOLERANCES:

LENGTH: ± 5/32"

WIDTH: ± 3/16"

DIAGONAL: ± 3/16"

**GORDON**<sup>®</sup>  
 ARCHITECTURAL+ENGINEERED SOLUTIONS

5023 Hazel Jones Rd.  
 Bossier City, LA 71111  
 800.747.8954  
 GORDON-INC.COM  
 sales@gordon-inc.com

**WALLS / CLADDINGS**  
**CORRUGATED - PANELS - VERTICAL**  
**PATTERN "A" PANELS**

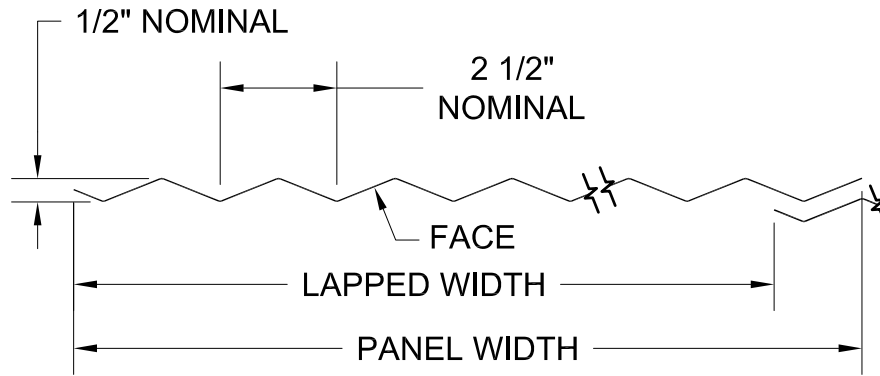

**ALUMINUM / STEEL**  
 MAXIMUM LENGTH: 120"

NOMINAL DIMENSIONS	
LAPPED WIDTH	PANEL WIDTH
42 3/4"	44 3/4"
54 3/4"	55 3/4"

AVAILABLE MATERIAL	
ALUMINUM	STEEL
.032"	22 GAUGE
	24 GAUGE
	26 GAUGE

NOTE: ALL DIMENSIONS ARE NOMINAL AND WILL VARY WITH DIFFERENT THICKNESSES AND TYPES OF MATERIAL.

STANDARD FACTORY TOLERANCES:

LENGTH: ± 5/32"

WIDTH: ± 3/16"

DIAGONAL: ± 3/16"

**GORDON**®  
 ARCHITECTURAL+ENGINEERED SOLUTIONS

5023 Hazel Jones Rd.  
 Bossier City, LA 71111  
 800.747.8954  
 GORDON-INC.COM  
 sales@gordon-inc.com

**WALLS / CLADDINGS**  
**CORRUGATED - PANELS - VERTICAL**  
**PATTERN "B" PANELS**

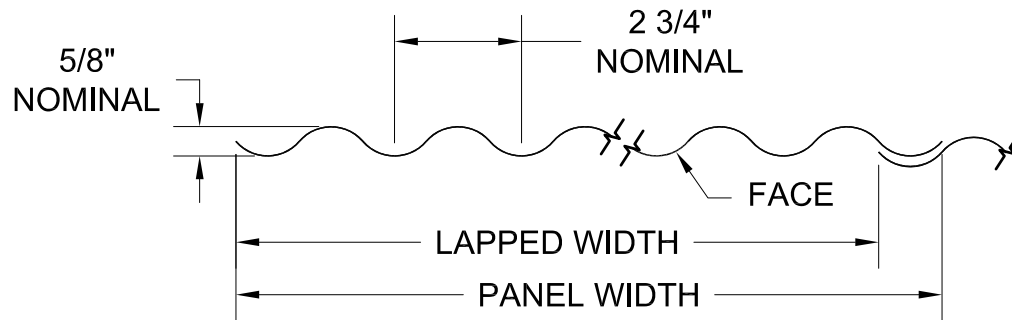

NOMINAL DIMENSIONS	
LAPPED WIDTH	PANEL WIDTH
40 3/8"	42"
51 5/8"	52 3/4"

**ALUMINUM**

.032" ALUMINUM MAXIMUM LENGTH: 144"  
 .063" ALUMINUM MAXIMUM LENGTH: 120"

**STEEL**

MAXIMUM LENGTH: 144"

AVAILABLE MATERIAL	
ALUMINUM	STEEL
.032"	22 GAUGE
.063"	24 GAUGE
	26 GAUGE

NOTE: ALL DIMENSIONS ARE NOMINAL AND WILL VARY WITH DIFFERENT THICKNESSES AND TYPES OF MATERIAL.

STANDARD FACTORY TOLERANCES:

- LENGTH: ± 5/32"
- WIDTH: ± 3/16"
- DIAGONAL: ± 3/16"



5023 Hazel Jones Rd.  
 Bossier City, LA 71111  
 800.747.8954  
 GORDON-INC.COM  
 sales@gordon-inc.com

**WALLS / CLADDINGS  
 CORRUGATED - PANELS - VERTICAL  
 PATTERN "C" PANELS**

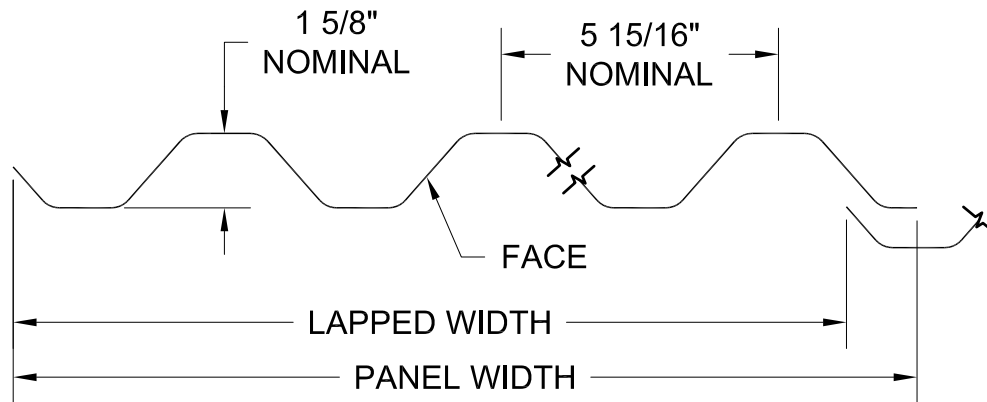

ALUMINUM / STEEL  
 MAXIMUM LENGTH: 120"

NOMINAL DIMENSIONS	
LAPPED WIDTH	PANEL WIDTH
47 1/2"	49 1/2"
38 5/8"	39 1/2"

AVAILABLE MATERIAL	
ALUMINUM	STEEL
.032"	22 GAUGE
	24 GAUGE
	26 GAUGE

NOTE: ALL DIMENSIONS ARE NOMINAL AND WILL VARY WITH DIFFERENT THICKNESSES AND TYPES OF MATERIAL.

STANDARD FACTORY TOLERANCES:

LENGTH: ± 5/32"

WIDTH: ± 3/16"

DIAGONAL: ± 3/16"

**GORDON**®  
 ARCHITECTURAL+ENGINEERED SOLUTIONS

5023 Hazel Jones Rd.  
 Bossier City, LA 71111  
 800.747.8954  
 GORDON-INC.COM  
 sales@gordon-inc.com

WALLS / CLADDINGS  
 CORRUGATED - PANELS - VERTICAL  
 PATTERN "D" PANEL

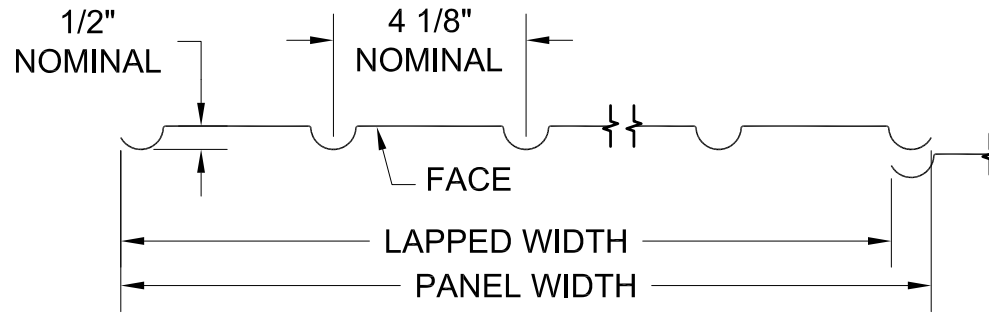

**EO - ALUMINUM / STEEL**  
 MAXIMUM LENGTH: 120"

NOMINAL DIMENSIONS	
LAPPED WIDTH	PANEL WIDTH
53 3/4"	54 3/4"

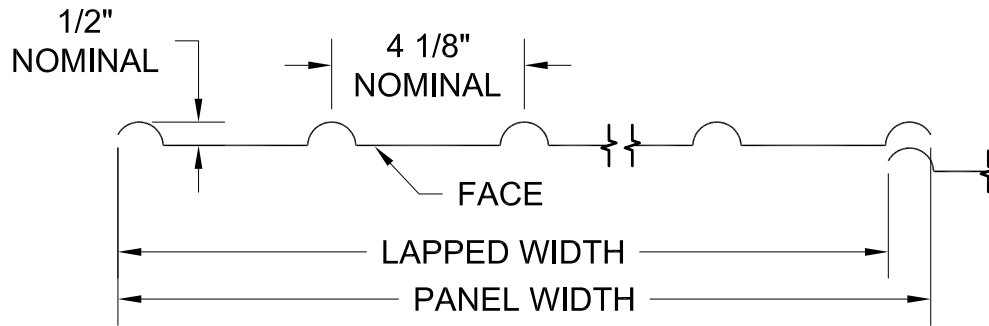

**EI - ALUMINUM / STEEL**  
 MAXIMUM LENGTH: 120"

AVAILABLE MATERIAL	
ALUMINUM	STEEL
.032"	24 GAUGE
	26 GAUGE

NOTE: ALL DIMENSIONS ARE NOMINAL AND WILL VARY WITH DIFFERENT THICKNESSES AND TYPES OF MATERIAL.

STANDARD FACTORY TOLERANCES:

LENGTH:  $\pm 5/32$ "

WIDTH:  $\pm 3/16$ "

DIAGONAL:  $\pm 3/16$ "

**GORDON**<sup>®</sup>  
 ARCHITECTURAL+ENGINEERED SOLUTIONS

5023 Hazel Jones Rd.  
 Bossier City, LA 71111  
 800.747.8954  
 GORDON-INC.COM  
 sales@gordon-inc.com

WALLS / CLADDINGS  
 CORRUGATED - PANELS - VERTICAL  
 PATTERN "E" PANELS

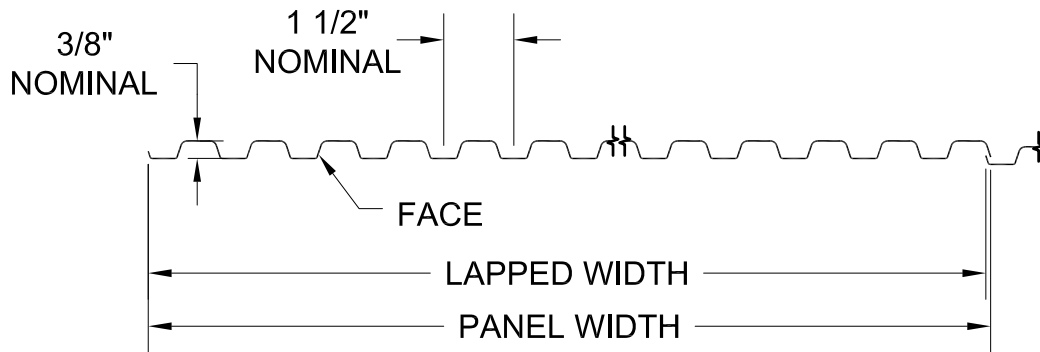

**ALUMINUM / STEEL**  
 MAXIMUM LENGTH: 144"

NOMINAL DIMENSIONS	
LAPPED WIDTH	PANEL WIDTH
39"	39 1/4"
49 7/8"	50"

AVAILABLE MATERIAL	
ALUMINUM	STEEL
.032"	24 GAUGE
	26 GAUGE

NOTE: ALL DIMENSIONS ARE NOMINAL AND WILL VARY WITH DIFFERENT THICKNESSES AND TYPES OF MATERIAL.

STANDARD FACTORY TOLERANCES:

LENGTH:  $\pm 5/32$ "

WIDTH:  $\pm 3/16$ "

DIAGONAL:  $\pm 3/16$ "

**GORDON**<sup>®</sup>  
 ARCHITECTURAL+ENGINEERED SOLUTIONS

5023 Hazel Jones Rd.  
 Bossier City, LA 71111  
 800.747.8954  
 GORDON-INC.COM  
 sales@gordon-inc.com

**WALLS / CLADDINGS**  
**CORRUGATED - PANELS - VERTICAL**  
**PATTERN "F" PANELS**

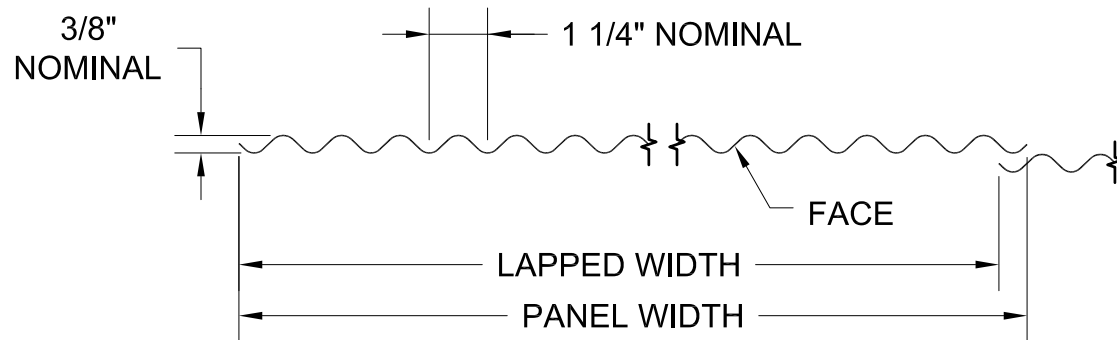

NOMINAL DIMENSIONS	
LAPPED WIDTH	PANEL WIDTH
40 1/2"	41 5/8"
51"	52"

AVAILABLE MATERIAL	
ALUMINUM	STEEL
.032"	22 GAUGE
	24 GAUGE
	26 GAUGE

ALUMINUM / STEEL  
 MAXIMUM LENGTH: 144"

NOTE: ALL DIMENSIONS ARE NOMINAL AND WILL VARY WITH DIFFERENT THICKNESSES AND TYPES OF MATERIAL.

STANDARD FACTORY TOLERANCES:

LENGTH: ± 5/32"

WIDTH: ± 3/16"

DIAGONAL: ± 3/16"

**GORDON**®  
 ARCHITECTURAL+ENGINEERED SOLUTIONS

5023 Hazel Jones Rd.  
 Bossier City, LA 71111  
 800.747.8954  
 GORDON-INC.COM  
 sales@gordon-inc.com

WALLS / CLADDINGS  
 CORRUGATED - PANELS - VERTICAL  
 PATTERN "J" PANELS



