

ALPRO VERTICAL CEILING SIDE MOUNT  
BAFFLE WITH EYEBOLT HARDWARE  
(INSULATION NOT SHOWN)

EYEBOLT  
HARDWARE  
TYP

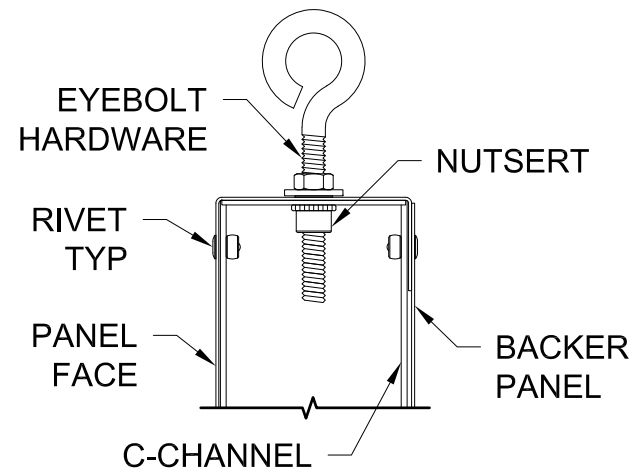
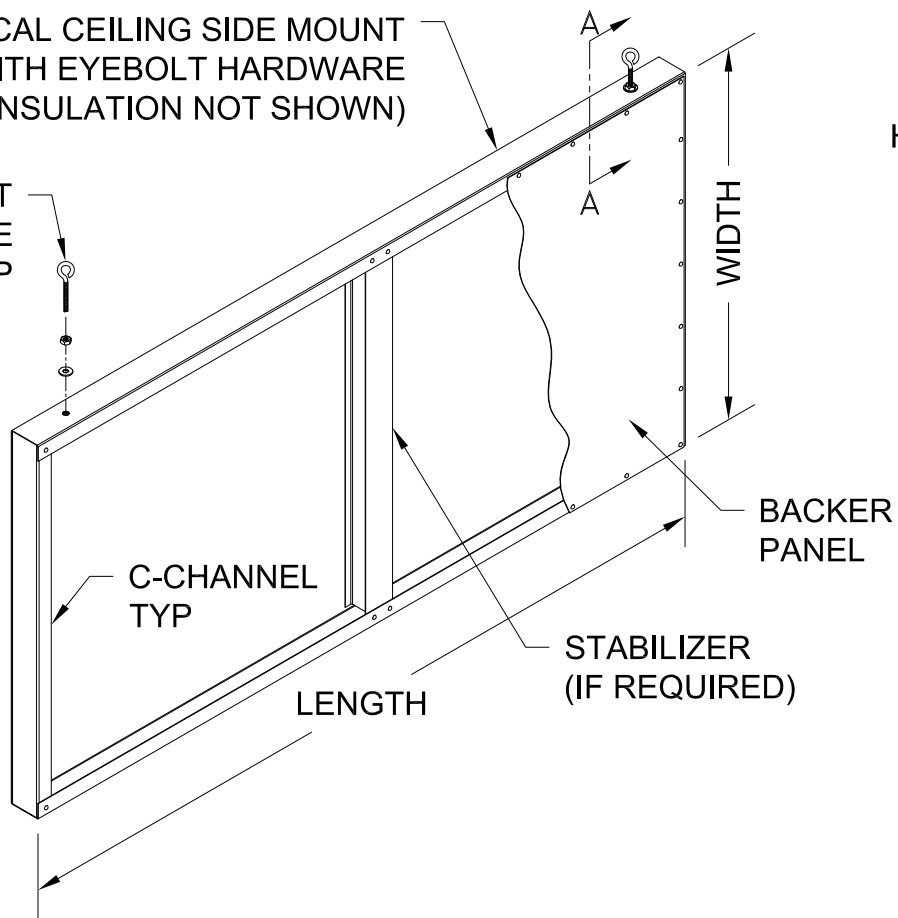

**GORDON**<sup>®</sup>  
ARCHITECTURAL+ENGINEERED SOLUTIONS

5023 Hazel Jones Rd.  
Bossier City, LA 71111  
800.747.8954  
GORDON-INC.COM  
sales@gordon-inc.com

CEILING  
CORRUGATED - BAFFLES - SUSPENDED  
VERTICAL FROM SIDE

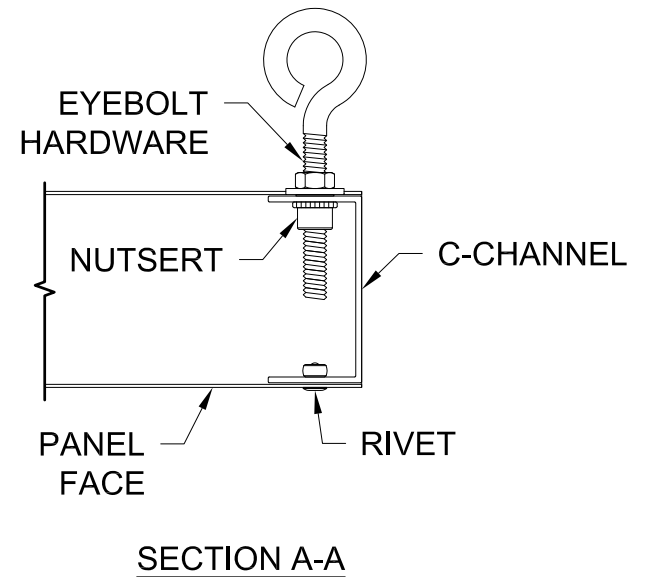
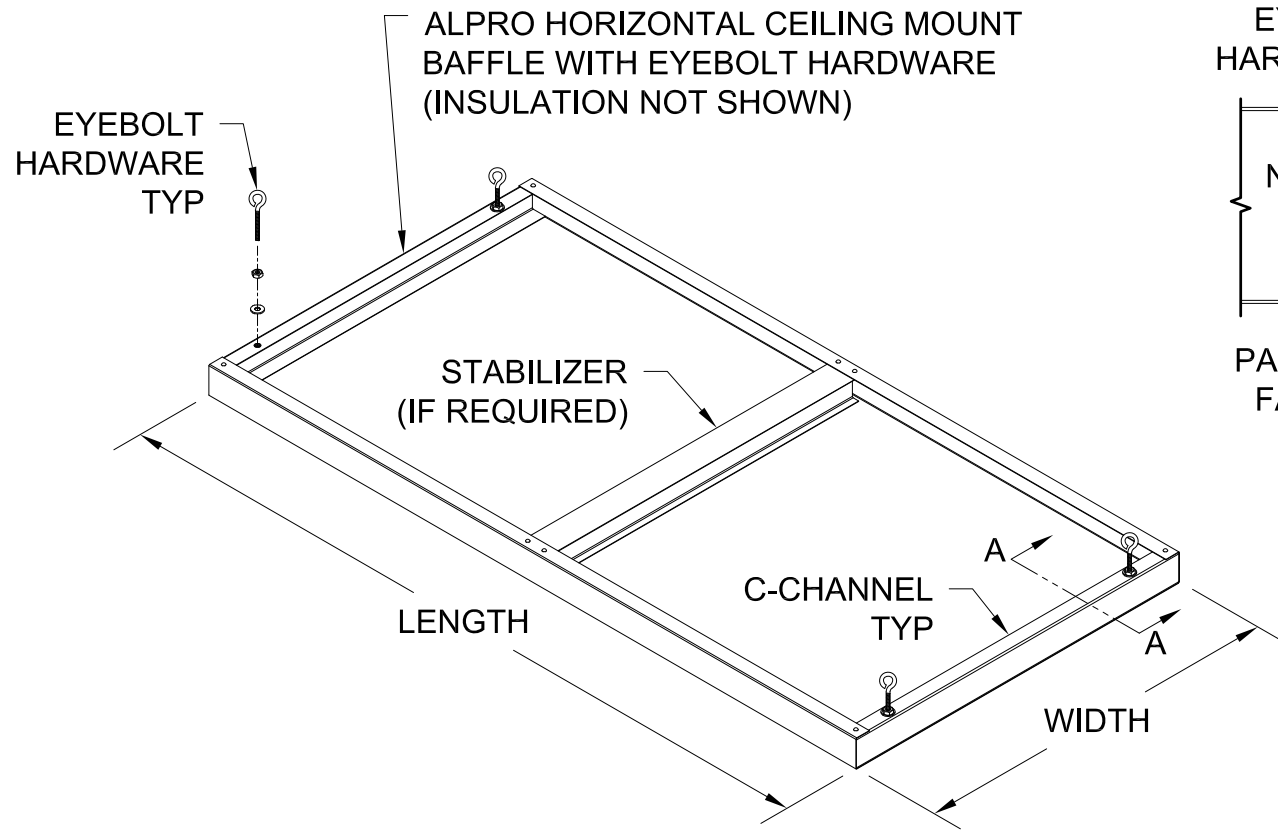

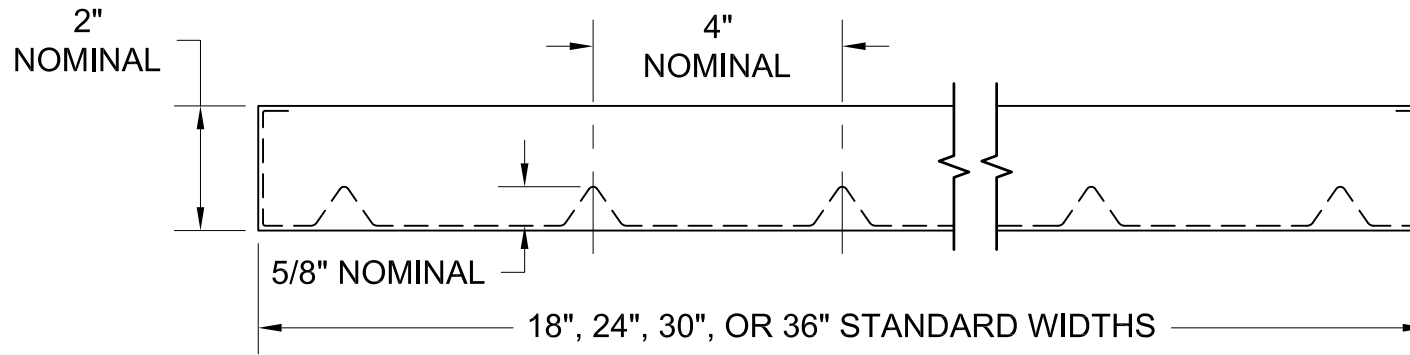

**AI-BAF**  
**ALUMINUM / STEEL**  
 MAXIMUM LENGTH: 120"

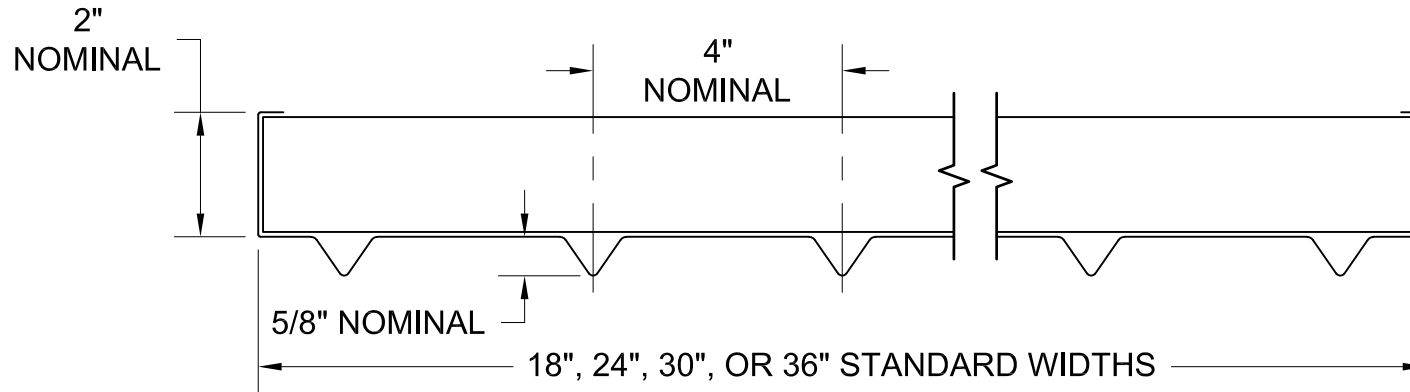

**AO-BAF**  
**ALUMINUM / STEEL**  
 MAXIMUM LENGTH: 120"

AVAILABLE MATERIAL	
ALUMINUM	STEEL
.032"	24 GAUGE
	26 GAUGE

NOTE: ALL DIMENSIONS SHOWN ARE NOMINAL.  
 STANDARD FACTORY TOLERANCES:  
 LENGTH:  $\pm 1/16"$   
 WIDTH:  $+0" -1/16"$

**GORDON**® ARCHITECTURAL+ENGINEERED SOLUTIONS  
 5023 Hazel Jones Rd.  
 Bossier City, LA 71111  
 800.747.8954  
 GORDON-INC.COM  
 sales@gordon-inc.com

**CEILING**  
**CORRUGATED - BAFFLES - SUSPENDED**  
**PATTERN "A"**

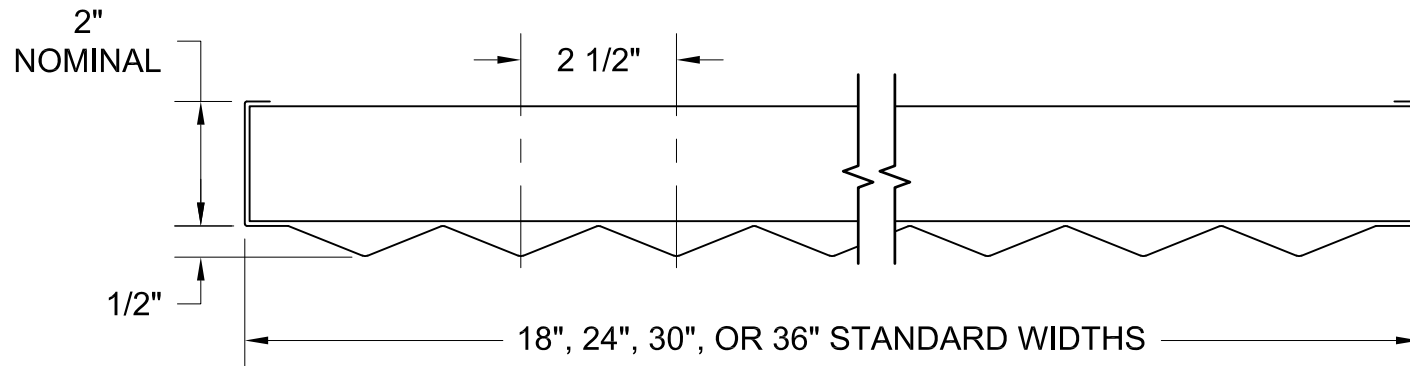

**B-BAF**  
**ALUMINUM / STEEL**  
 MAXIMUM LENGTH: 120"

AVAILABLE MATERIAL	
ALUMINUM	STEEL
.032"	22 GAUGE
	24 GAUGE
	26 GAUGE

NOTE: ALL DIMENSIONS SHOWN ARE NOMINAL.  
 STANDARD FACTORY TOLERANCES:  
 LENGTH:  $\pm 1/16"$   
 WIDTH: +0" -1/16"

**GORDON**®  
 ARCHITECTURAL+ENGINEERED SOLUTIONS

5023 Hazel Jones Rd.  
 Bossier City, LA 71111  
 800.747.8954  
 GORDON-INC.COM  
 sales@gordon-inc.com

**CEILING**  
**CORRUGATED - BAFFLES - SUSPENDED**  
**PATTERN "B"**

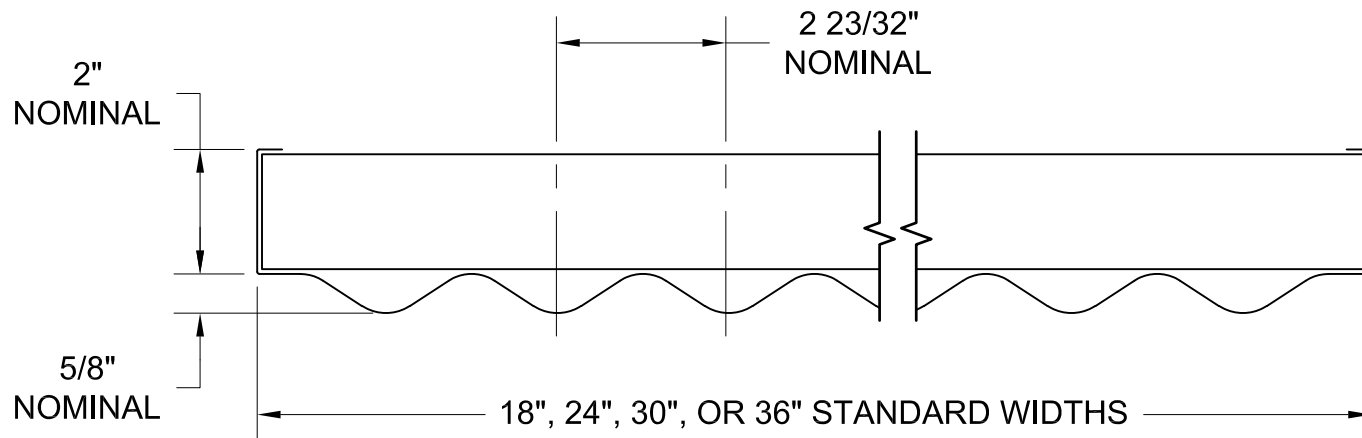

**C-BAF**  
**ALUMINUM / STEEL**  
 MAXIMUM LENGTH: 120"

AVAILABLE MATERIAL	
ALUMINUM	STEEL
.032"	22 GAUGE
	24 GAUGE
	26 GAUGE

NOTE: ALL DIMENSIONS SHOWN ARE NOMINAL.  
 STANDARD FACTORY TOLERANCES:  
 LENGTH:  $\pm 1/16"$   
 WIDTH:  $+0" -1/16"$

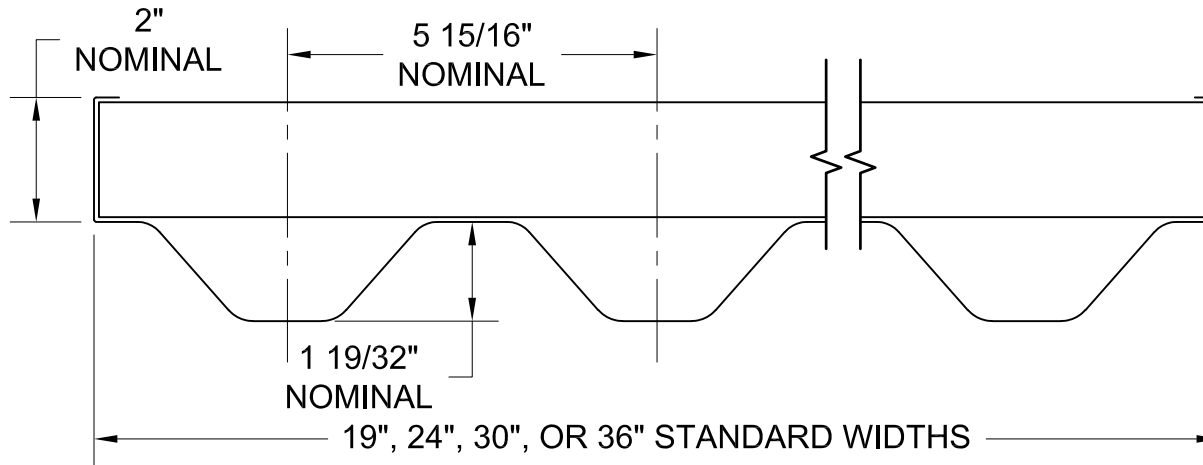

**D-BAF**  
**ALUMINUM / STEEL**  
 MAXIMUM LENGTH: 120"

AVAILABLE MATERIAL	
ALUMINUM	STEEL
.032"	22 GAUGE
	24 GAUGE
	26 GAUGE

NOTE: ALL DIMENSIONS SHOWN ARE NOMINAL.  
 STANDARD FACTORY TOLERANCES:  
 LENGTH:  $\pm 1/16"$   
 WIDTH:  $+0" -1/16"$

**GORDON**®  
 ARCHITECTURAL+ENGINEERED SOLUTIONS

5023 Hazel Jones Rd.  
 Bossier City, LA 71111  
 800.747.8954  
 GORDON-INC.COM  
 sales@gordon-inc.com

**CEILING**  
**CORRUGATED - BAFFLES - SUSPENDED**  
**PATTERN "D"**

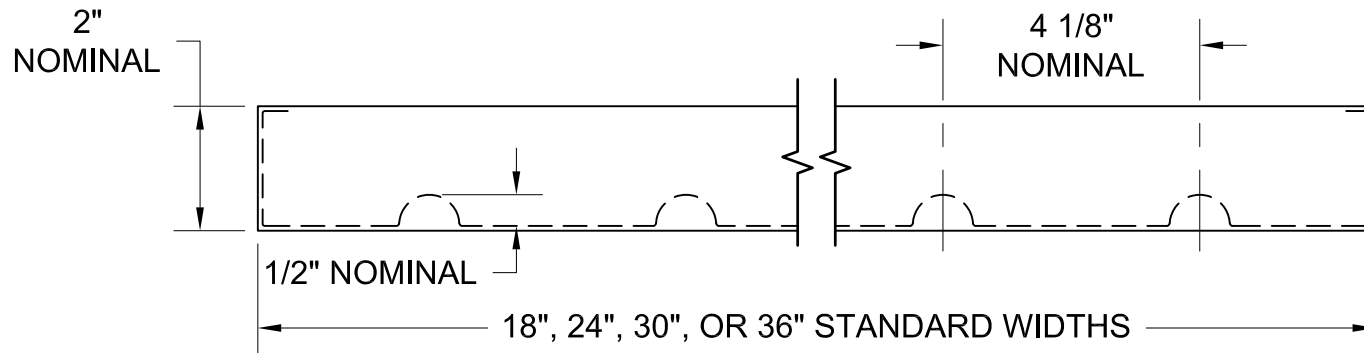

**EI-BAF**  
**ALUMINUM / STEEL**  
 MAXIMUM LENGTH: 120"

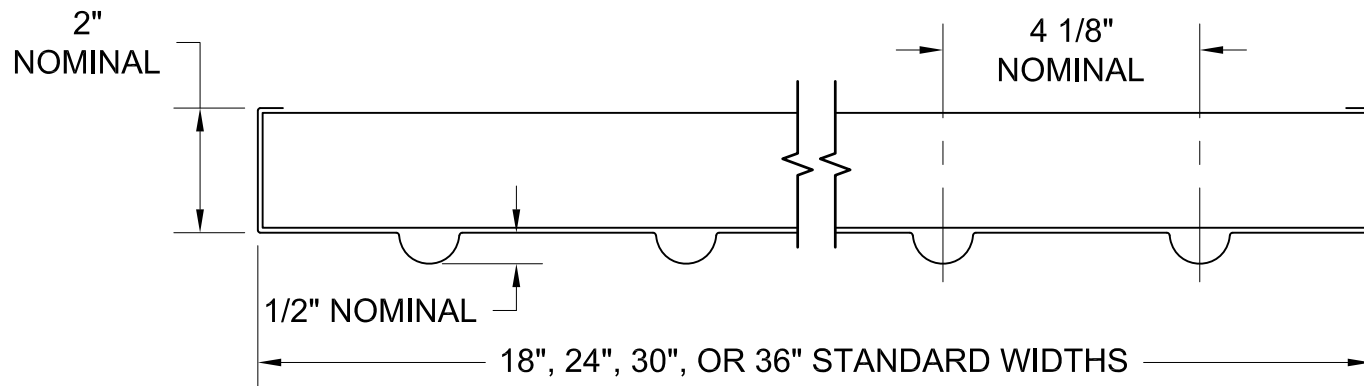

**EO-BAF**  
**ALUMINUM / STEEL**  
 MAXIMUM LENGTH: 120"

AVAILABLE MATERIAL	
ALUMINUM	STEEL
.032"	24 GAUGE
	26 GAUGE

NOTE: ALL DIMENSIONS SHOWN ARE NOMINAL.  
 STANDARD FACTORY TOLERANCES:  
 LENGTH:  $\pm 1/16"$   
 WIDTH:  $+0" -1/16"$

**GORDON**<sup>®</sup>  
 ARCHITECTURAL+ENGINEERED SOLUTIONS

5023 Hazel Jones Rd.  
 Bossier City, LA 71111  
 800.747.8954  
 GORDON-INC.COM  
 sales@gordon-inc.com

**CEILING**  
**CORRUGATED - BAFFLES - SUSPENDED**  
**PATTERN "E"**



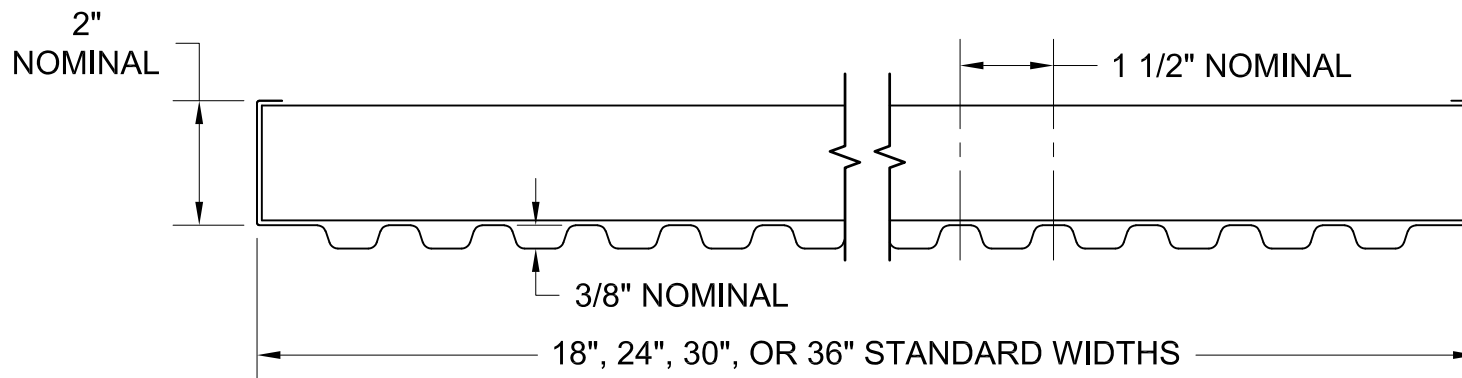

**F-BAF**  
**ALUMINUM / STEEL**  
 MAXIMUM LENGTH: 120"

NOTE: ALL DIMENSIONS SHOWN ARE NOMINAL.  
 STANDARD FACTORY TOLERANCES:  
 LENGTH:  $\pm 1/16"$   
 WIDTH:  $+0" -1/16"$

AVAILABLE MATERIAL	
ALUMINUM	STEEL
.032"	24 GAUGE
	26 GAUGE

**GORDON**® ARCHITECTURAL+ENGINEERED SOLUTIONS  
 5023 Hazel Jones Rd.  
 Bossier City, LA 71111  
 800.747.8954  
 GORDON-INC.COM  
 sales@gordon-inc.com

**CEILING**  
**CORRUGATED - BAFFLES - SUSPENDED**  
**PATTERN "F"**

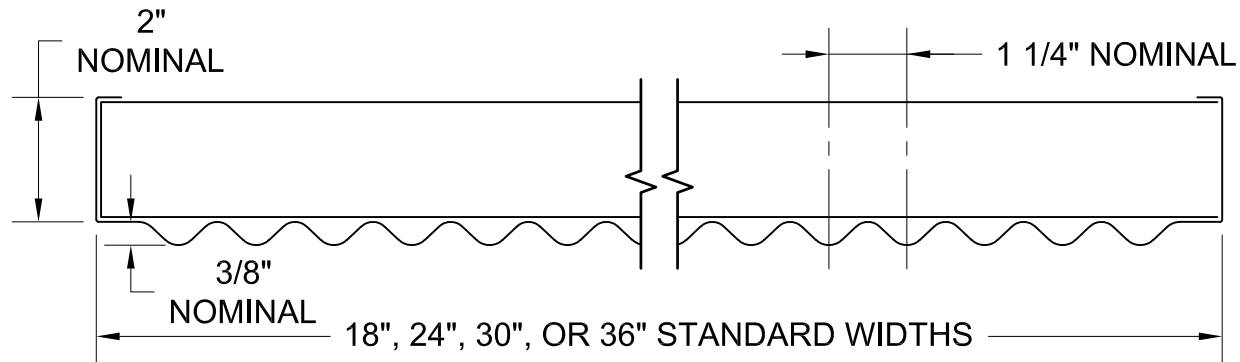

**J-BAF**  
**ALUMINUM / STEEL**  
 MAXIMUM LENGTH: 120"

AVAILABLE MATERIAL	
ALUMINUM	STEEL
.032"	22 GAUGE
	24 GAUGE
	26 GAUGE

NOTE: ALL DIMENSIONS SHOWN ARE NOMINAL.  
 STANDARD FACTORY TOLERANCES:  
 LENGTH:  $\pm 1/16"$   
 WIDTH:  $+0" -1/16"$

**GORDON**®  
 ARCHITECTURAL+ENGINEERED SOLUTIONS

5023 Hazel Jones Rd.  
 Bossier City, LA 71111  
 800.747.8954  
 GORDON-INC.COM  
 sales@gordon-inc.com

**CEILING**  
**CORRUGATED - BAFFLES - SUSPENDED**  
**PATTERN "J"**

2"  
NOMINAL

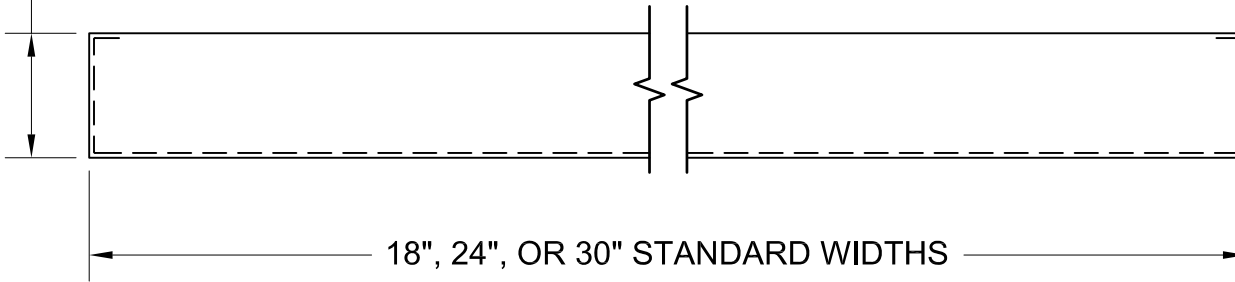

**FLAT-BAF-I**  
**ALUMINUM / STEEL**  
 MAXIMUM LENGTH: 120"

2"  
NOMINAL

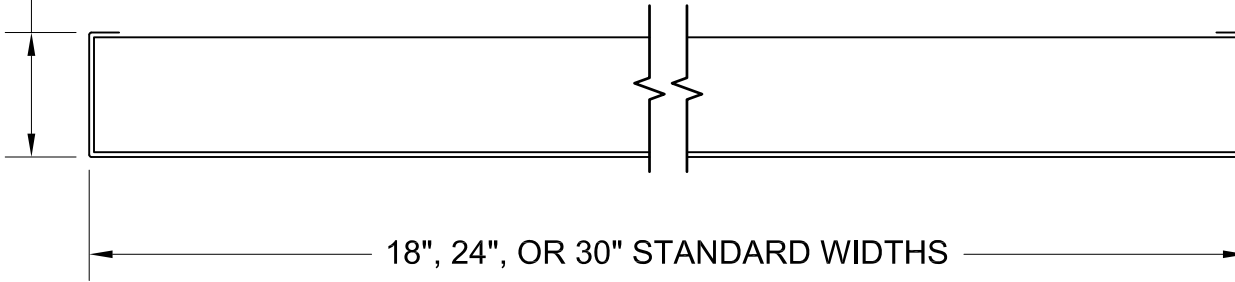

**FLAT-BAF-O**  
**ALUMINUM / STEEL**  
 MAXIMUM LENGTH: 120"

NOTE: ALL DIMENSIONS SHOWN ARE NOMINAL.  
 STANDARD FACTORY TOLERANCES:  
 LENGTH:  $\pm 1/16"$   
 WIDTH:  $+0" -1/16"$

AVAILABLE MATERIAL	
ALUMINUM	STEEL
.063"	22 GAUGE

**GORDON**<sup>®</sup>  
 ARCHITECTURAL+ENGINEERED SOLUTIONS

5023 Hazel Jones Rd.  
 Bossier City, LA 71111  
 800.747.8954  
 GORDON-INC.COM  
 sales@gordon-inc.com

**CEILING**  
**CORRUGATED - BAFFLES - SUSPENDED**  
**PATTERN "FLAT"**