

SECTION A-A

CORRUGATED VERTICAL CEILING END MOUNT BAFFLE WITH EYEBOLT HARDWARE (INSULATION NOT SHOWN)

CORRUGATED VERTICAL CEILING SIDE
MOUNT BAFFLE WITH EYEBOLT HARDWARE
(INSULATION NOT SHOWN)

EYEBOLT
HARDWARE
TYP

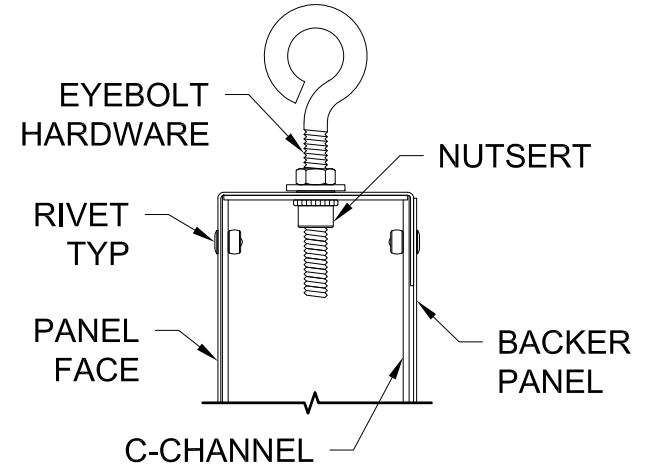
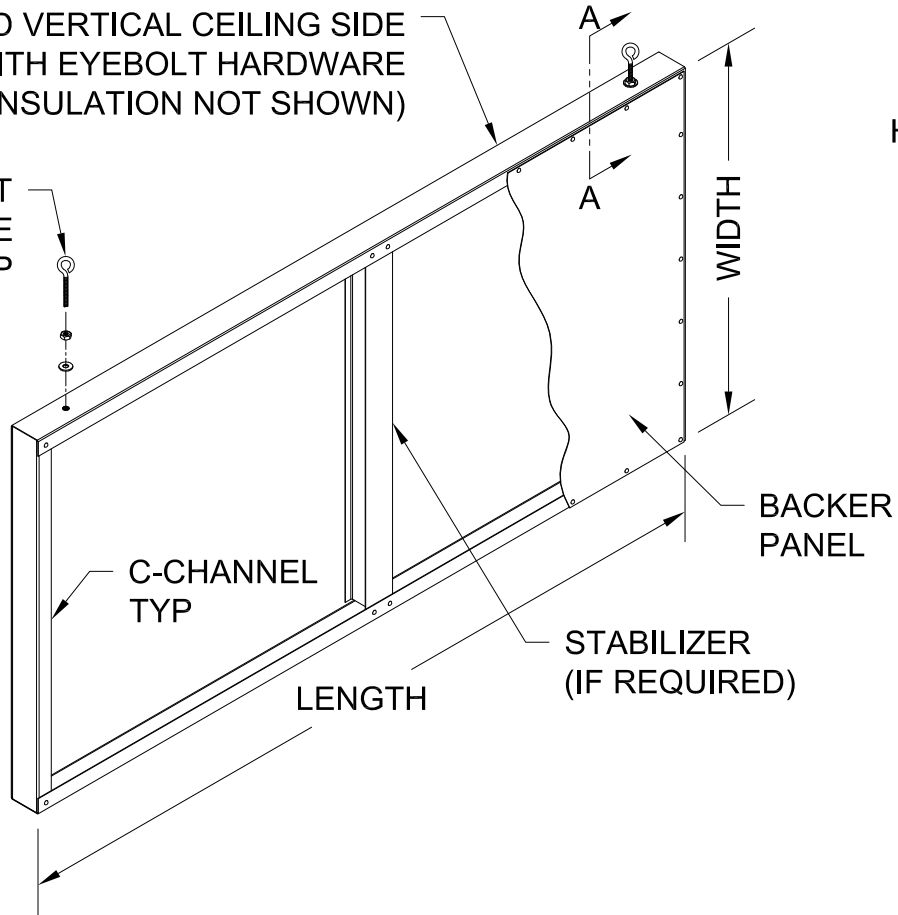

SECTION A-A

GORDON[®]
ARCHITECTURAL+ENGINEERED SOLUTIONS

5023 Hazel Jones Rd.
Bossier City, LA 71111
800.747.8954
GORDON-INC.COM
sales@gordon-inc.com

INDUSTRIAL CEILING SYSTEMS
CORRUGATED - BAFFLES - SUSPENDED
VERTICAL FROM SIDE

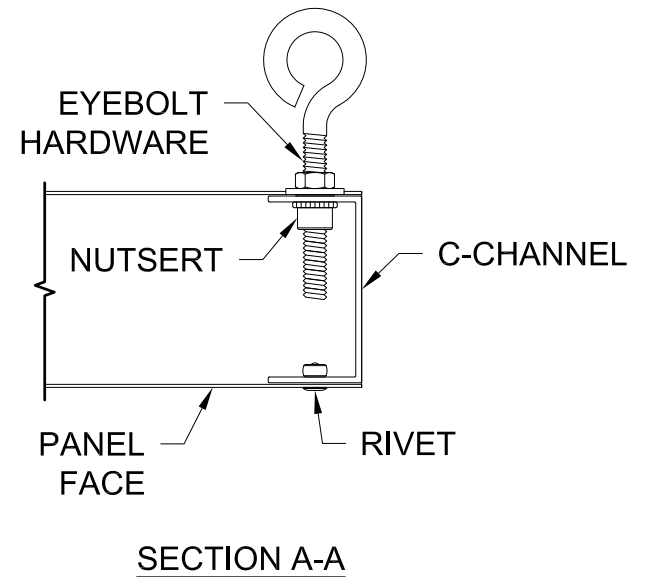
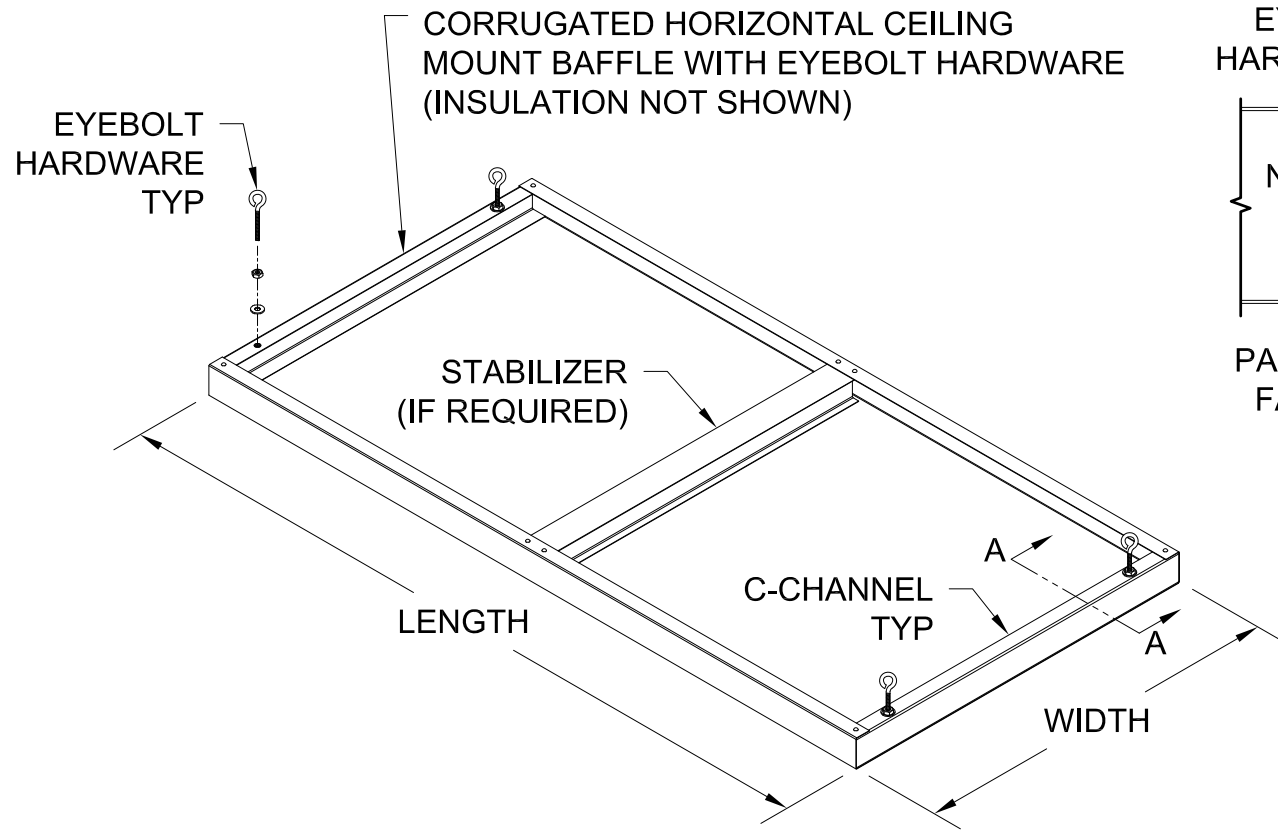

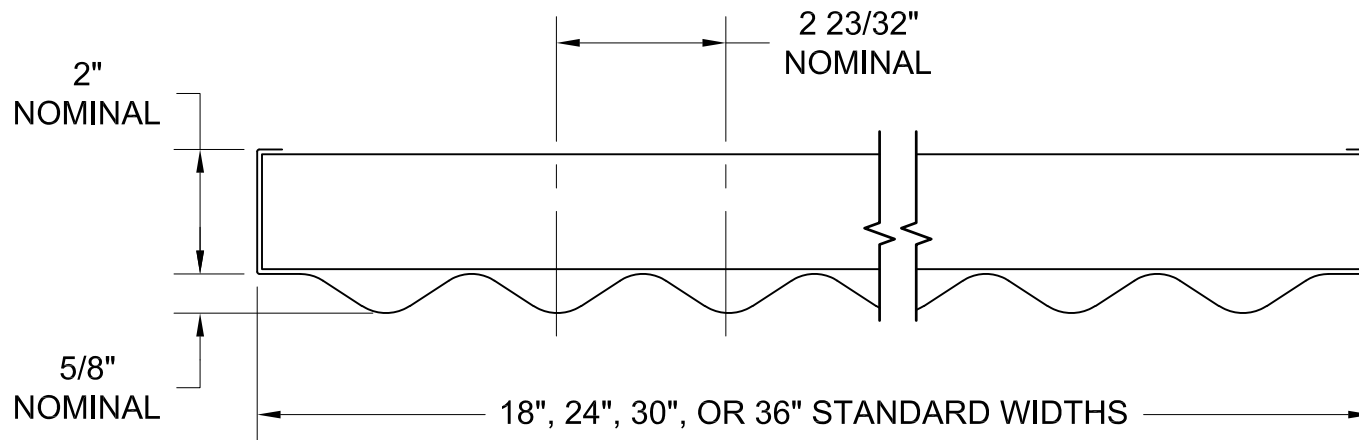

C-BAF
ALUMINUM / STEEL
 MAXIMUM LENGTH: 120"

AVAILABLE MATERIAL	
ALUMINUM	STEEL
.032"	22 GAUGE
	24 GAUGE
	26 GAUGE

NOTE: ALL DIMENSIONS SHOWN ARE NOMINAL.
 STANDARD FACTORY TOLERANCES:
 LENGTH: ± 1/16"
 WIDTH: +0" -1/16"

GORDON® ARCHITECTURAL+ENGINEERED SOLUTIONS
 5023 Hazel Jones Rd.
 Bossier City, LA 71111
 800.747.8954
 GORDON-INC.COM
 sales@gordon-inc.com

INDUSTRIAL CEILING SYSTEMS
CORRUGATED - BAFFLES - SUSPENDED
PATTERN "C"

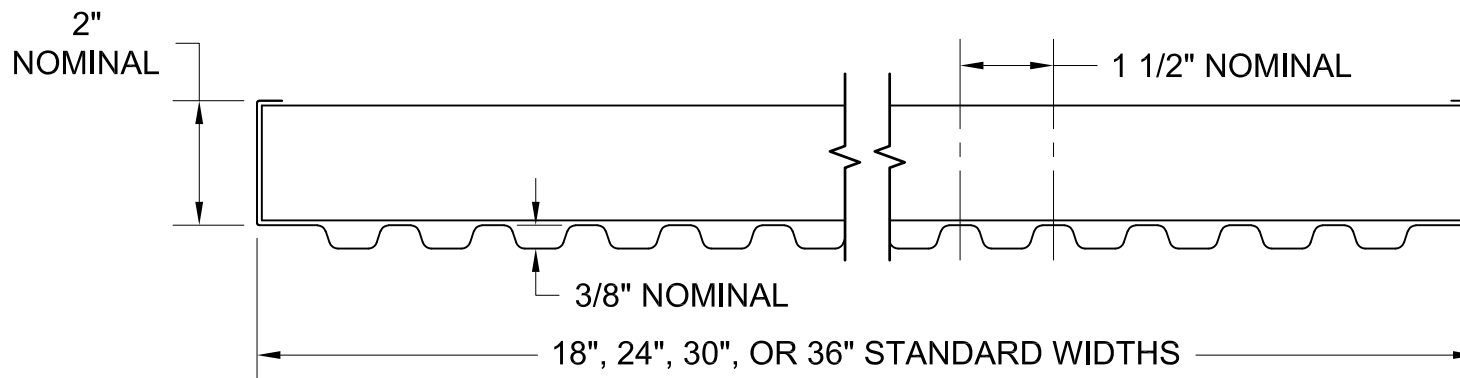

F-BAF
ALUMINUM / STEEL
 MAXIMUM LENGTH: 120"

NOTE: ALL DIMENSIONS SHOWN ARE NOMINAL.
 STANDARD FACTORY TOLERANCES:
 LENGTH: $\pm 1/16"$
 WIDTH: $+0" -1/16"$

AVAILABLE MATERIAL	
ALUMINUM	STEEL
.032"	24 GAUGE
	26 GAUGE

GORDON®
 ARCHITECTURAL+ENGINEERED SOLUTIONS

5023 Hazel Jones Rd.
 Bossier City, LA 71111
 800.747.8954
 GORDON-INC.COM
 sales@gordon-inc.com

INDUSTRIAL CEILING SYSTEMS
CORRUGATED - BAFFLES - SUSPENDED
PATTERN "F"

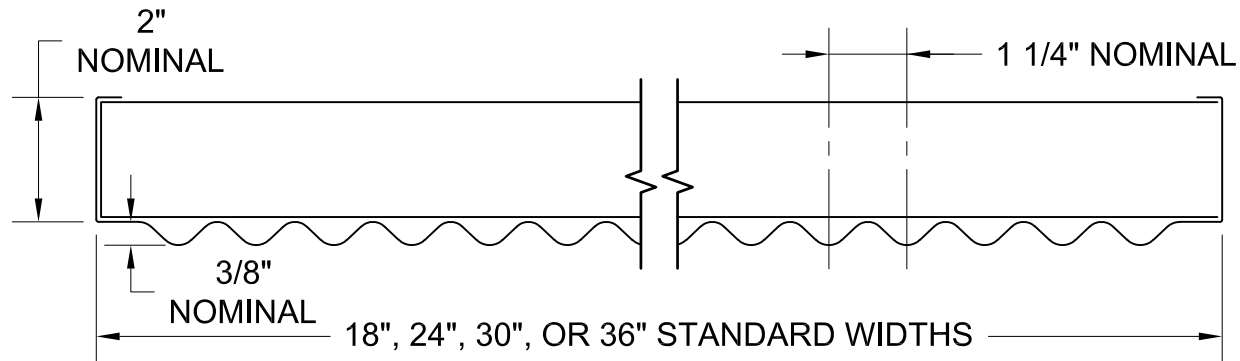

J-BAF
ALUMINUM / STEEL
 MAXIMUM LENGTH: 120"

AVAILABLE MATERIAL	
ALUMINUM	STEEL
.032"	22 GAUGE
	24 GAUGE
	26 GAUGE

NOTE: ALL DIMENSIONS SHOWN ARE NOMINAL.
 STANDARD FACTORY TOLERANCES:
 LENGTH: $\pm 1/16"$
 WIDTH: $+0" -1/16"$

GORDON[®]
 ARCHITECTURAL+ENGINEERED SOLUTIONS

5023 Hazel Jones Rd.
 Bossier City, LA 71111
 800.747.8954
 GORDON-INC.COM
 sales@gordon-inc.com

INDUSTRIAL CEILING SYSTEMS
CORRUGATED - BAFFLES - SUSPENDED
PATTERN "J"

2"
NOMINAL

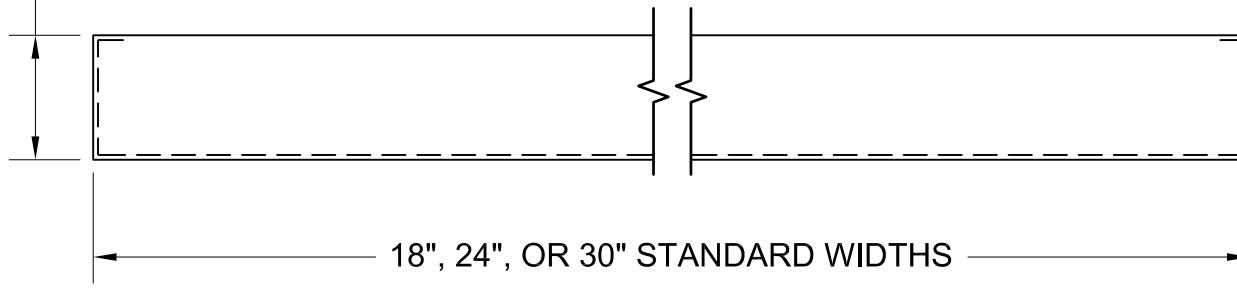

18", 24", OR 30" STANDARD WIDTHS

FLAT-BAF-I
ALUMINUM / STEEL
 MAXIMUM LENGTH: 120"

2"
NOMINAL

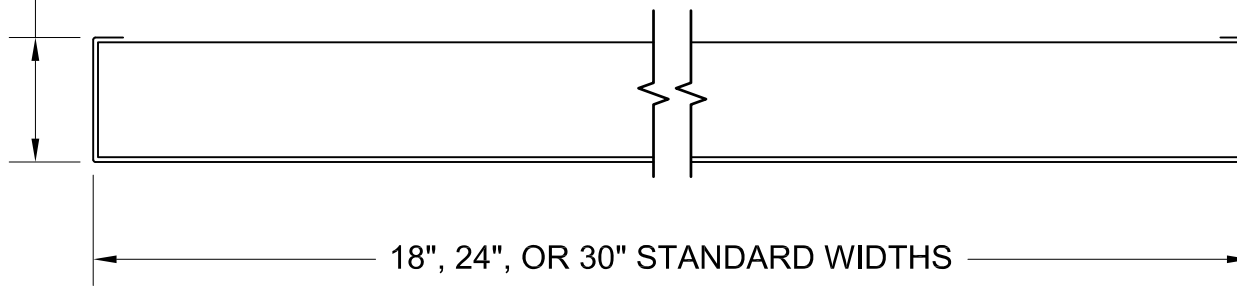

18", 24", OR 30" STANDARD WIDTHS

FLAT-BAF-O
ALUMINUM / STEEL
 MAXIMUM LENGTH: 120"

NOTE: ALL DIMENSIONS SHOWN ARE NOMINAL.
 STANDARD FACTORY TOLERANCES:
 LENGTH: $\pm 1/16"$
 WIDTH: $+0" -1/16"$

AVAILABLE MATERIAL	
ALUMINUM	STEEL
.063"	22 GAUGE

GORDON® ARCHITECTURAL+ENGINEERED SOLUTIONS
 5023 Hazel Jones Rd.
 Bossier City, LA 71111
 800.747.8954
 GORDON-INC.COM
 sales@gordon-inc.com

INDUSTRIAL CEILING SYSTEMS
CORRUGATED - BAFFLES - SUSPENDED
PATTERN "FLAT"