

GORDON[®]
ARCHITECTURAL+ENGINEERED SOLUTIONS

5023 Hazel Jones Rd.
Bossier City, LA 71111
800.747.8954
GORDON-INC.COM
sales@gordon-inc.com

INDUSTRIAL CEILING SYSTEMS
CORRUGATED - BAFFLES - MOUNTED
Z-CLIP INSTALLATION

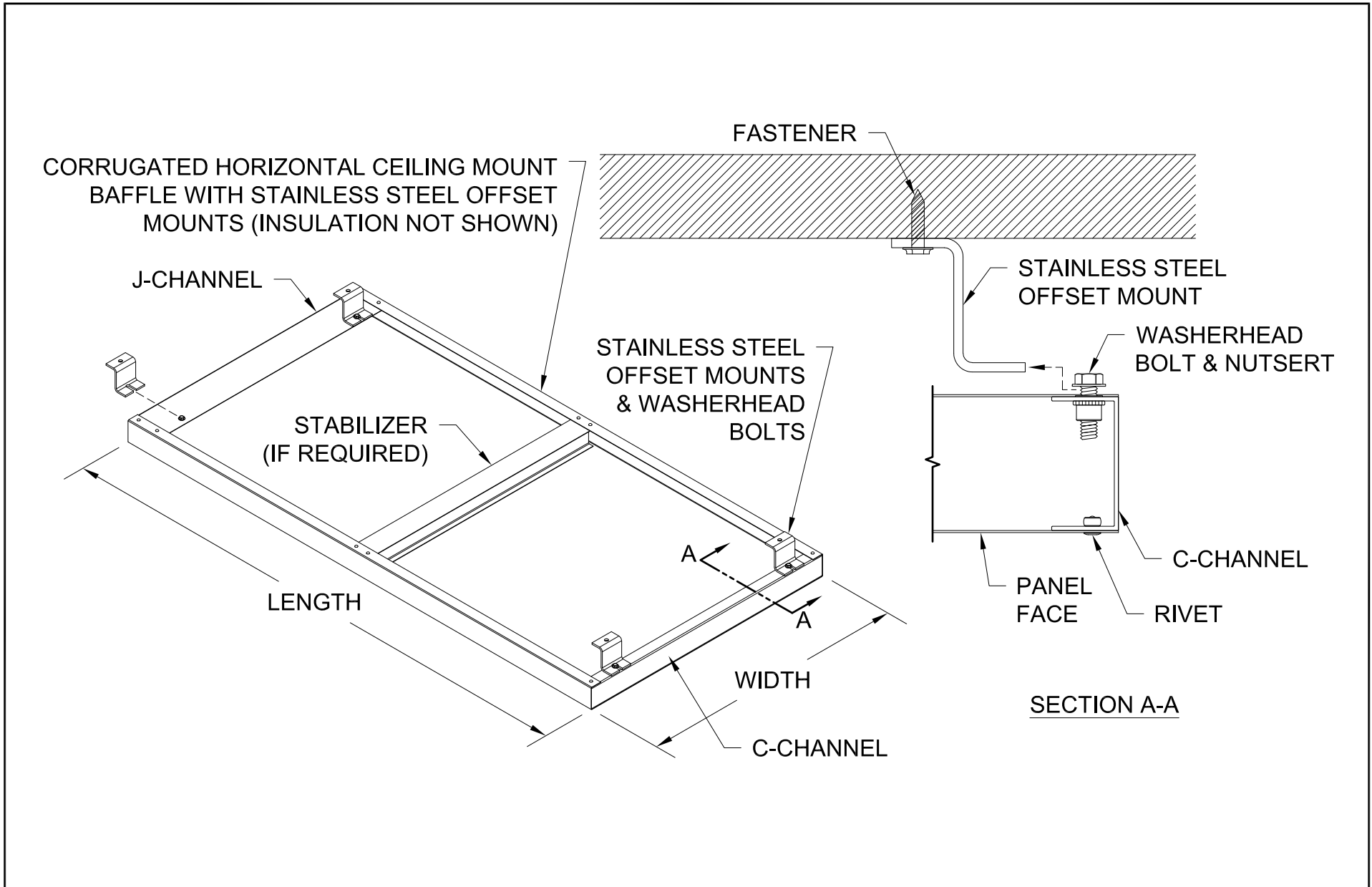

GORDON[®]
ARCHITECTURAL+ENGINEERED SOLUTIONS

5023 Hazel Jones Rd.
Bossier City, LA 71111
800.747.8954
GORDON-INC.COM
sales@gordon-inc.com

INDUSTRIAL CEILING SYSTEMS
CORRUGATED - BAFFLES - MOUNTED
OFFSET SS INSTALLATION

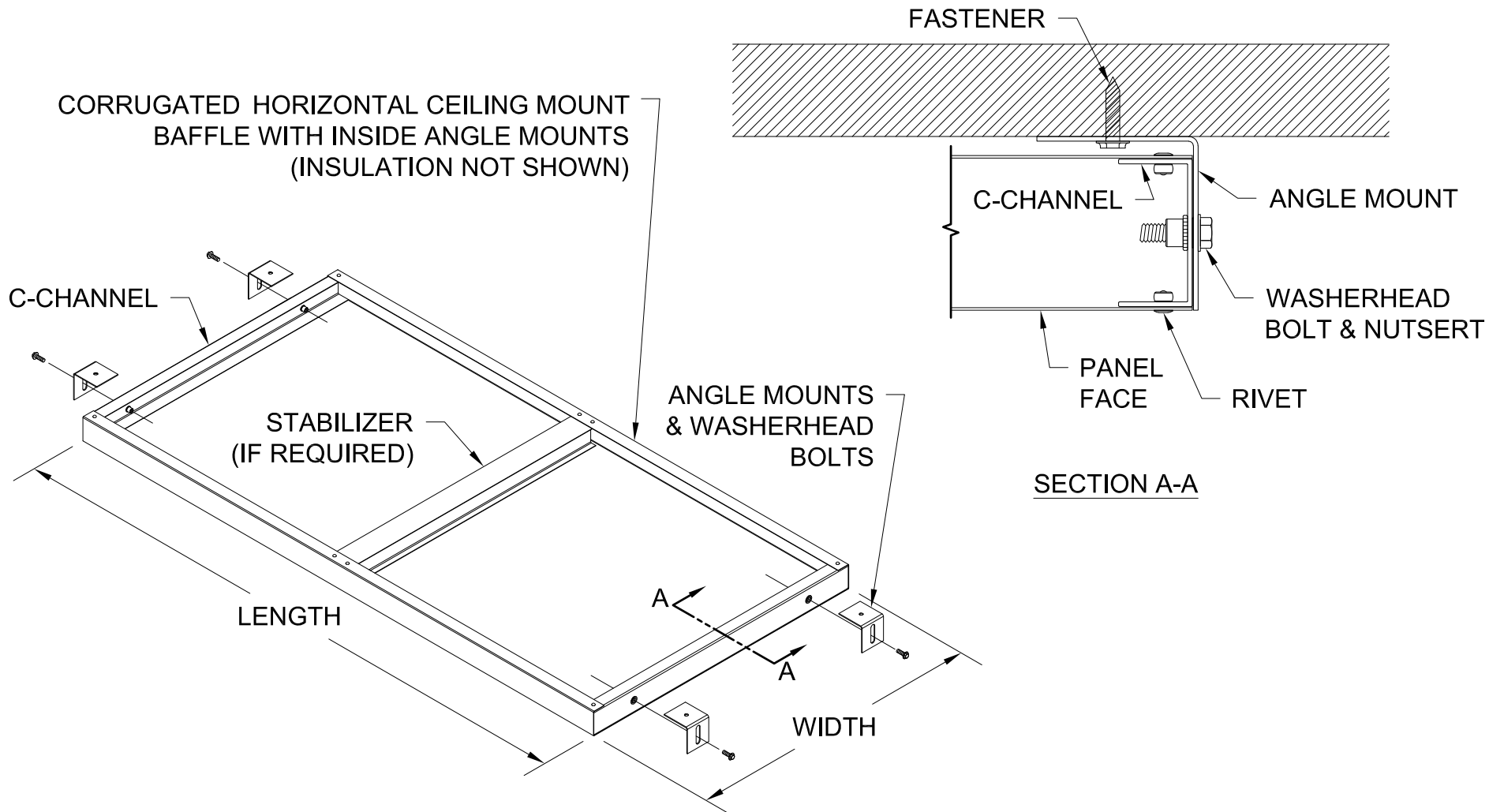

GORDON[®]
ARCHITECTURAL+ENGINEERED SOLUTIONS

5023 Hazel Jones Rd.
Bossier City, LA 71111
800.747.8954
GORDON-INC.COM
sales@gordon-inc.com

INDUSTRIAL CEILING SYSTEMS
CORRUGATED - BAFFLES - MOUNTED
INSIDE ANGLE INSTALLATION

CORRUGATED HORIZONTAL CEILING MOUNT
BAFFLE WITH OUTSIDE ANGLE MOUNTS
(INSULATION NOT SHOWN)

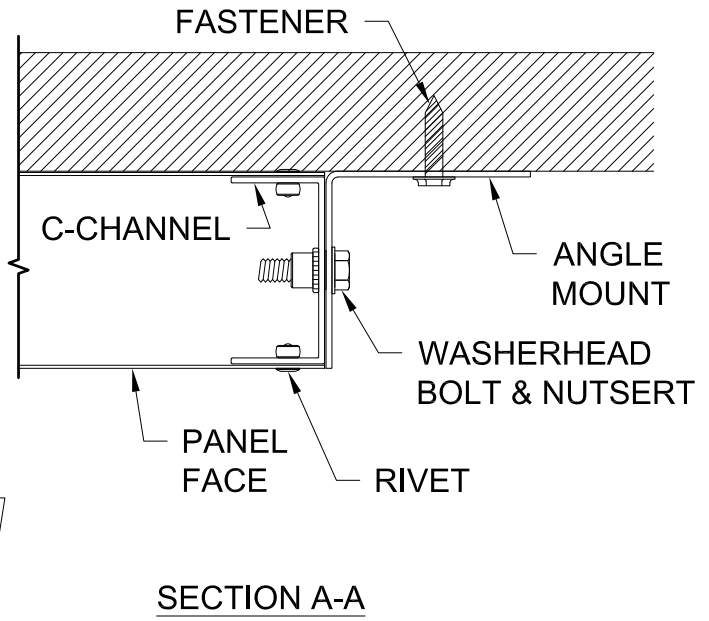
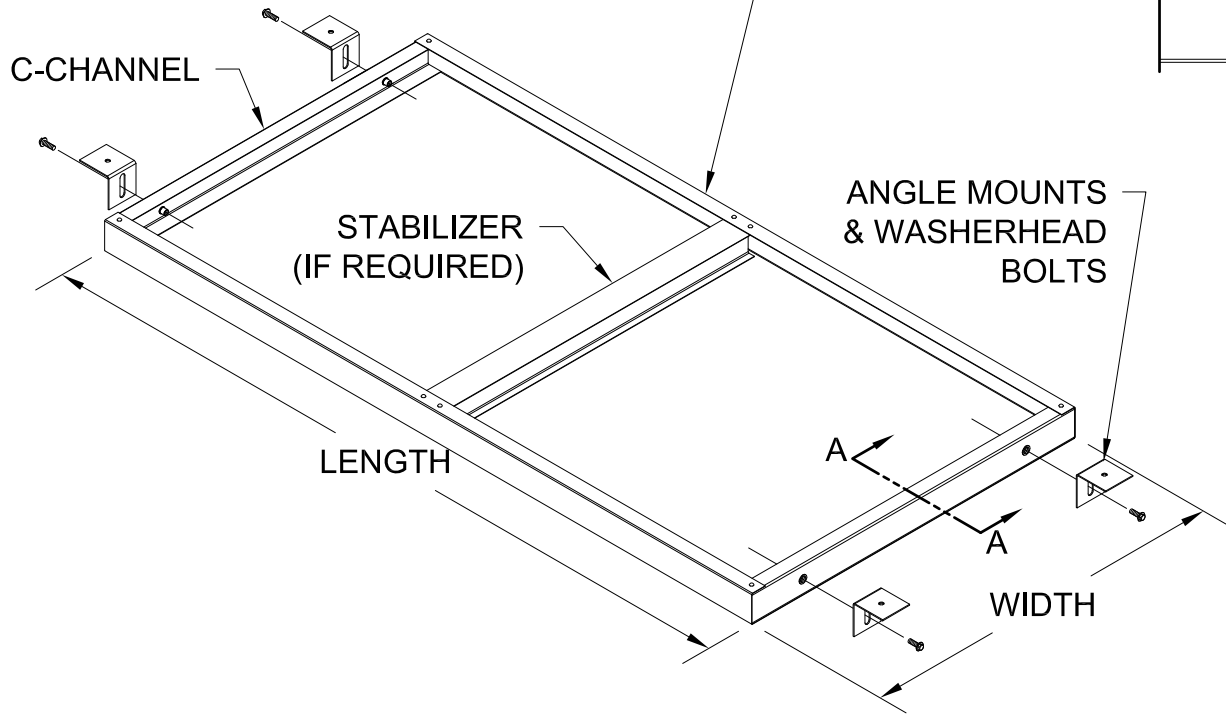

GORDON[®]
ARCHITECTURAL+ENGINEERED SOLUTIONS

5023 Hazel Jones Rd.
Bossier City, LA 71111
800.747.8954
GORDON-INC.COM
sales@gordon-inc.com

INDUSTRIAL CEILING SYSTEMS
CORRUGATED - BAFFLES - MOUNTED
OUTSIDE ANGLE INSTALLATION

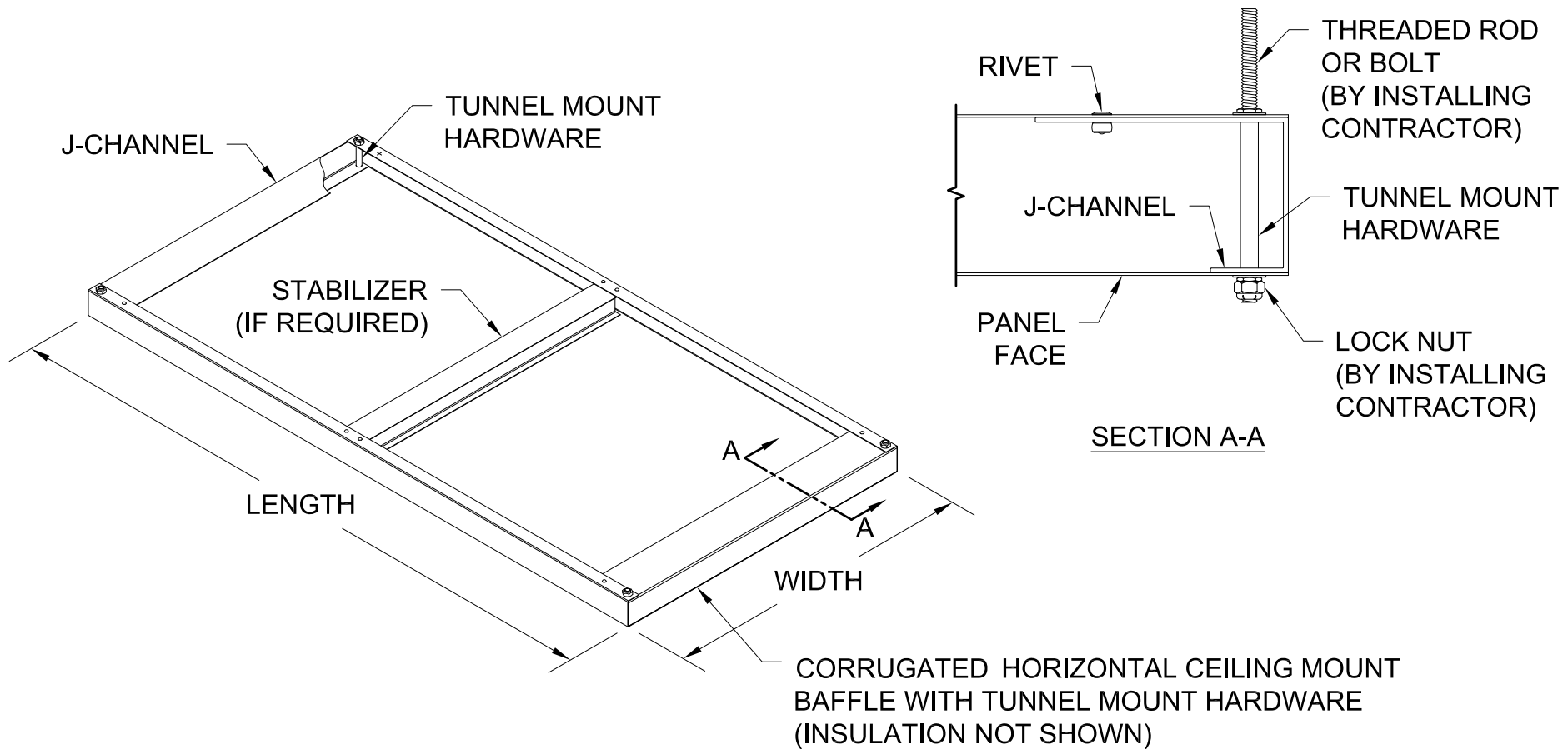

GORDON® ARCHITECTURAL+ENGINEERED SOLUTIONS

5023 Hazel Jones Rd.
 Bossier City, LA 71111
 800.747.8954
 GORDON-INC.COM
 sales@gordon-inc.com

**INDUSTRIAL CEILING SYSTEMS
 CORRUGATED - BAFFLES - MOUNTED
 TUNNEL INSTALLATION**

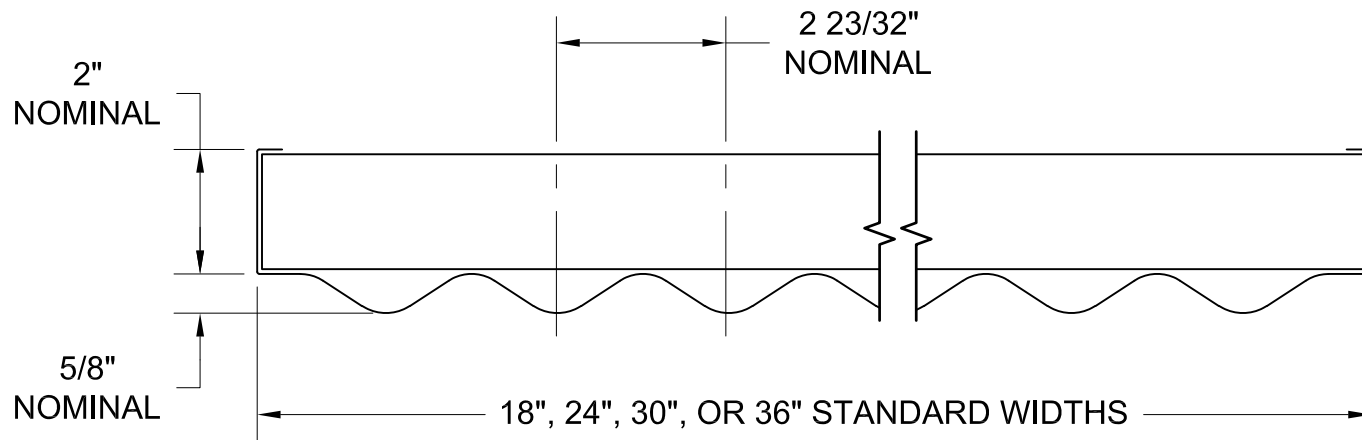

C-BAF
ALUMINUM / STEEL
 MAXIMUM LENGTH: 120"

AVAILABLE MATERIAL	
ALUMINUM	STEEL
.032"	22 GAUGE
	24 GAUGE
	26 GAUGE

NOTE: ALL DIMENSIONS SHOWN ARE NOMINAL.
 STANDARD FACTORY TOLERANCES:
 LENGTH: ± 1/16"
 WIDTH: +0" -1/16"

GORDON®
 ARCHITECTURAL+ENGINEERED SOLUTIONS

5023 Hazel Jones Rd.
 Bossier City, LA 71111
 800.747.8954
 GORDON-INC.COM
 sales@gordon-inc.com

INDUSTRIAL CEILING SYSTEMS
CORRUGATED - BAFFLES - MOUNTED
PATTERN "C"

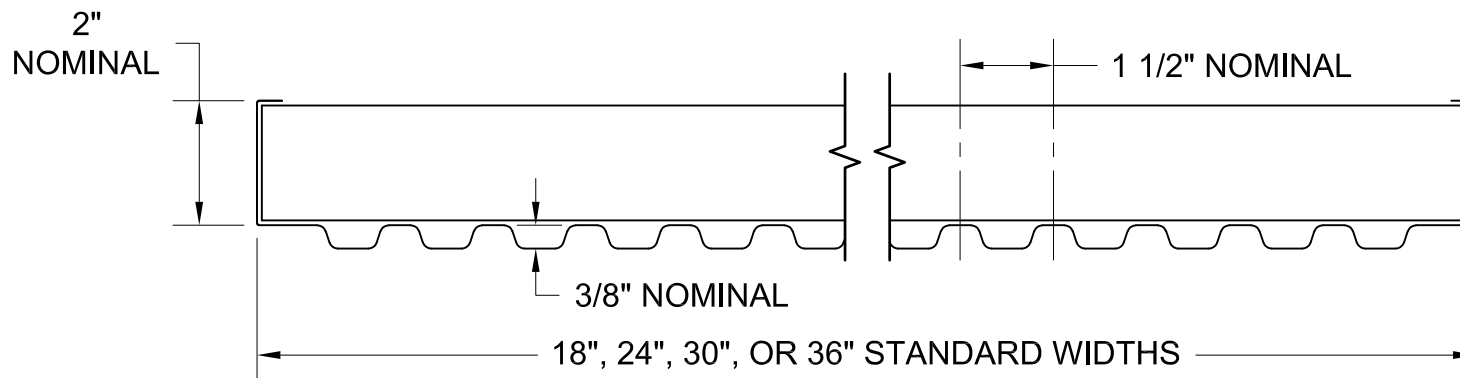

F-BAF
ALUMINUM / STEEL
 MAXIMUM LENGTH: 120"

NOTE: ALL DIMENSIONS SHOWN ARE NOMINAL.
 STANDARD FACTORY TOLERANCES:
 LENGTH: ± 1/16"
 WIDTH: +0" -1/16"

AVAILABLE MATERIAL	
ALUMINUM	STEEL
.032"	24 GAUGE
	26 GAUGE

GORDON®
 ARCHITECTURAL+ENGINEERED SOLUTIONS

5023 Hazel Jones Rd.
 Bossier City, LA 71111
 800.747.8954
 GORDON-INC.COM
 sales@gordon-inc.com

INDUSTRIAL CEILING SYSTEMS
CORRUGATED - BAFFLES - MOUNTED
PATTERN "F"

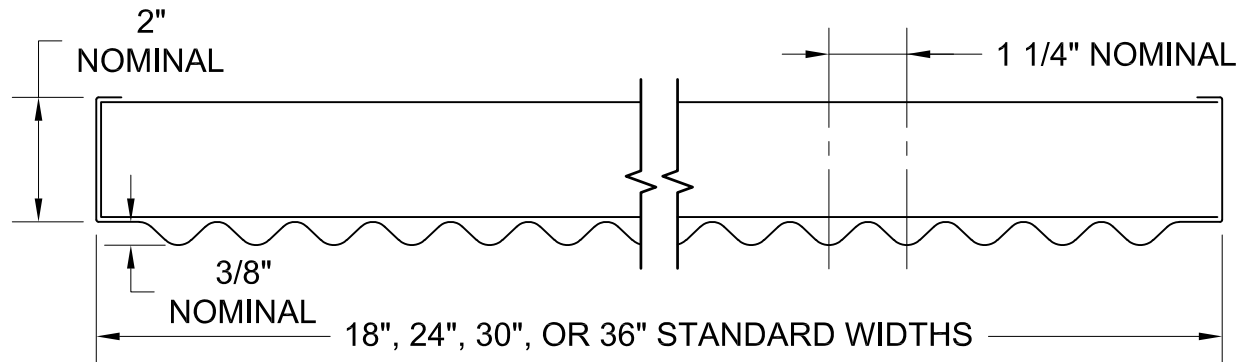

J-BAF
ALUMINUM / STEEL
 MAXIMUM LENGTH: 120"

AVAILABLE MATERIAL	
ALUMINUM	STEEL
.032"	22 GAUGE
	24 GAUGE
	26 GAUGE

NOTE: ALL DIMENSIONS SHOWN ARE NOMINAL.
 STANDARD FACTORY TOLERANCES:
 LENGTH: ± 1/16"
 WIDTH: +0" -1/16"

GORDON®
 ARCHITECTURAL+ENGINEERED SOLUTIONS

5023 Hazel Jones Rd.
 Bossier City, LA 71111
 800.747.8954
 GORDON-INC.COM
 sales@gordon-inc.com

INDUSTRIAL CEILING SYSTEMS
CORRUGATED - BAFFLES - MOUNTED
PATTERN "J"

2"
NOMINAL

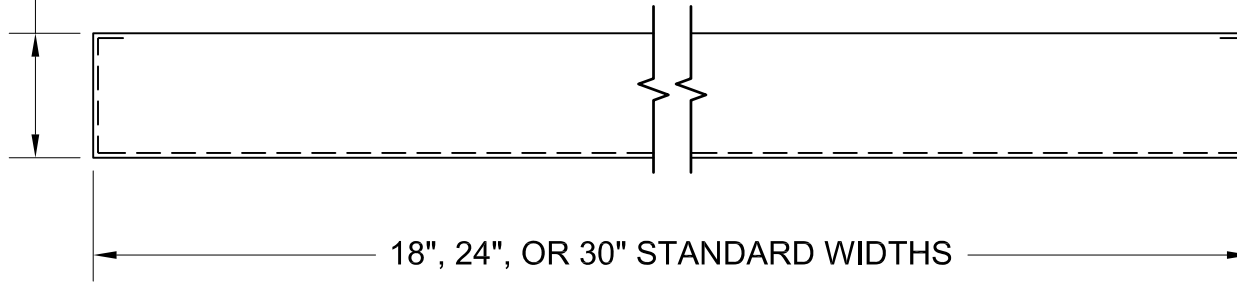

18", 24", OR 30" STANDARD WIDTHS

FLAT-BAF-I
ALUMINUM / STEEL
 MAXIMUM LENGTH: 120"

2"
NOMINAL

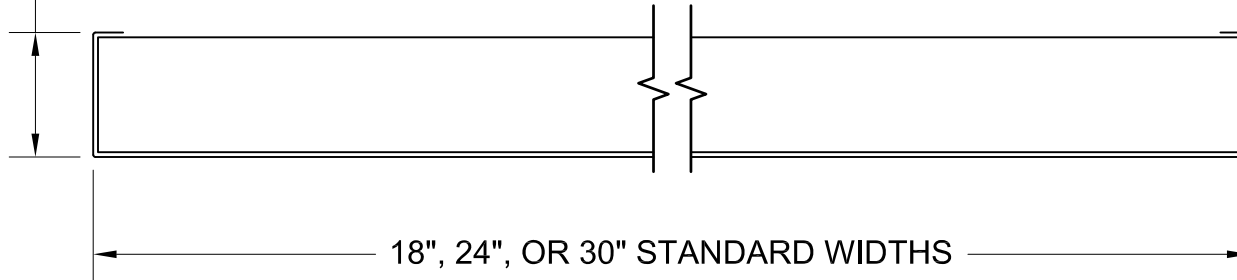

18", 24", OR 30" STANDARD WIDTHS

FLAT-BAF-O
ALUMINUM / STEEL
 MAXIMUM LENGTH: 120"

NOTE: ALL DIMENSIONS SHOWN ARE NOMINAL.
 STANDARD FACTORY TOLERANCES:
 LENGTH: $\pm 1/16"$
 WIDTH: $+0" -1/16"$

AVAILABLE MATERIAL	
ALUMINUM	STEEL
.063"	22 GAUGE

GORDON[®]
 ARCHITECTURAL+ENGINEERED SOLUTIONS

5023 Hazel Jones Rd.
 Bossier City, LA 71111
 800.747.8954
 GORDON-INC.COM
 sales@gordon-inc.com

INDUSTRIAL CEILING SYSTEMS
CORRUGATED - BAFFLES - MOUNTED
PATTERN "FLAT"