

GORDON[®]
ARCHITECTURAL+ENGINEERED SOLUTIONS

5023 Hazel Jones Rd.
Bossier City, LA 71111
800.747.8954
GORDON-INC.COM
sales@gordon-inc.com

CREATIVE MATERIALS FOR ACOUSTICS
ACOUSTICAL BAFFLES
STAGGERED CONFIGURATION

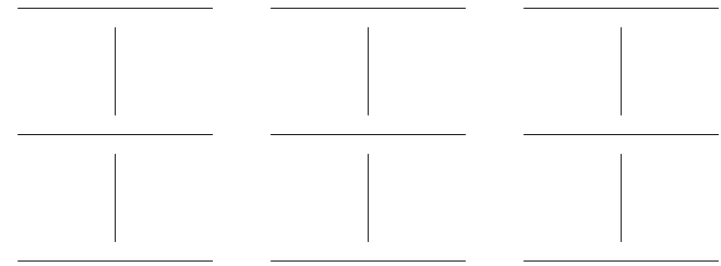
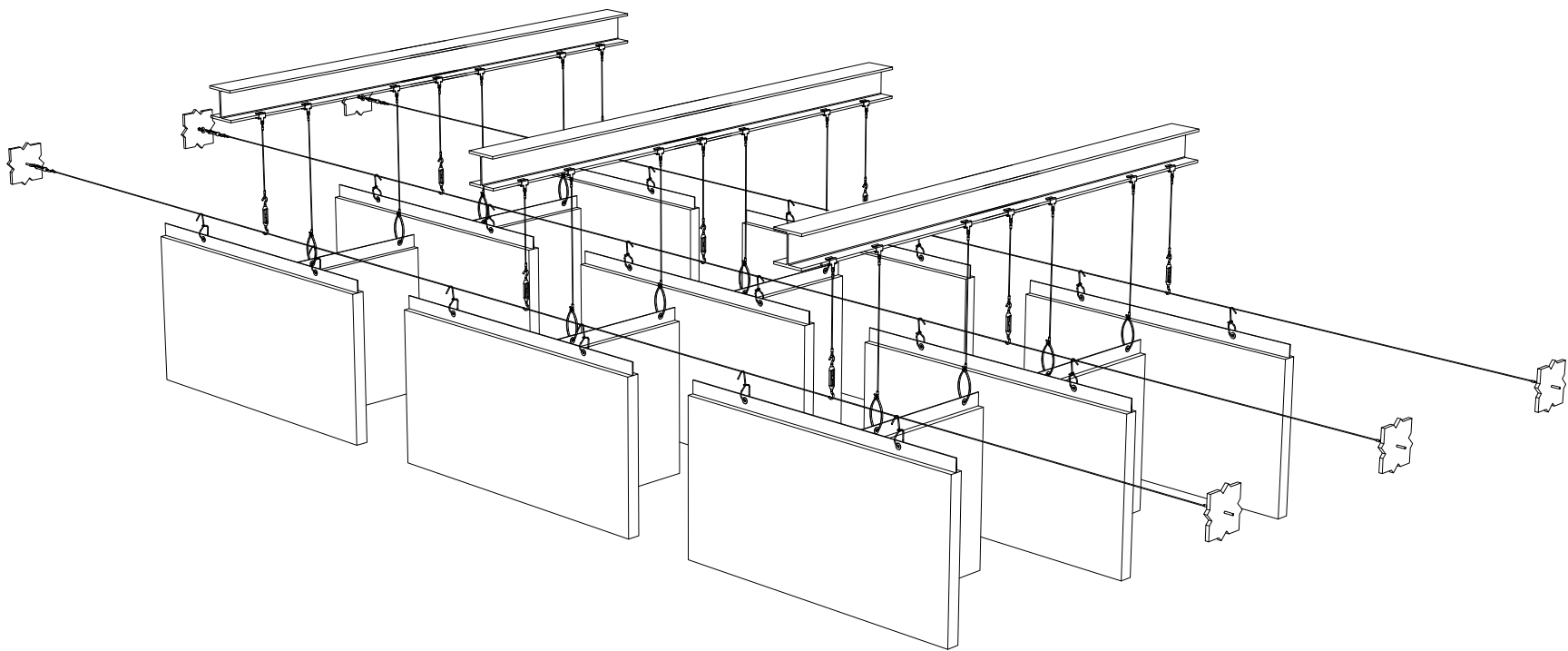

GORDON®
ARCHITECTURAL+ENGINEERED SOLUTIONS

5023 Hazel Jones Rd.
Bossier City, LA 71111
800.747.8954
GORDON-INC.COM
sales@gordon-inc.com

CREATIVE MATERIALS FOR ACOUSTICS
ACOUSTICAL BAFFLES
STRAIGHT CONFIGURATION

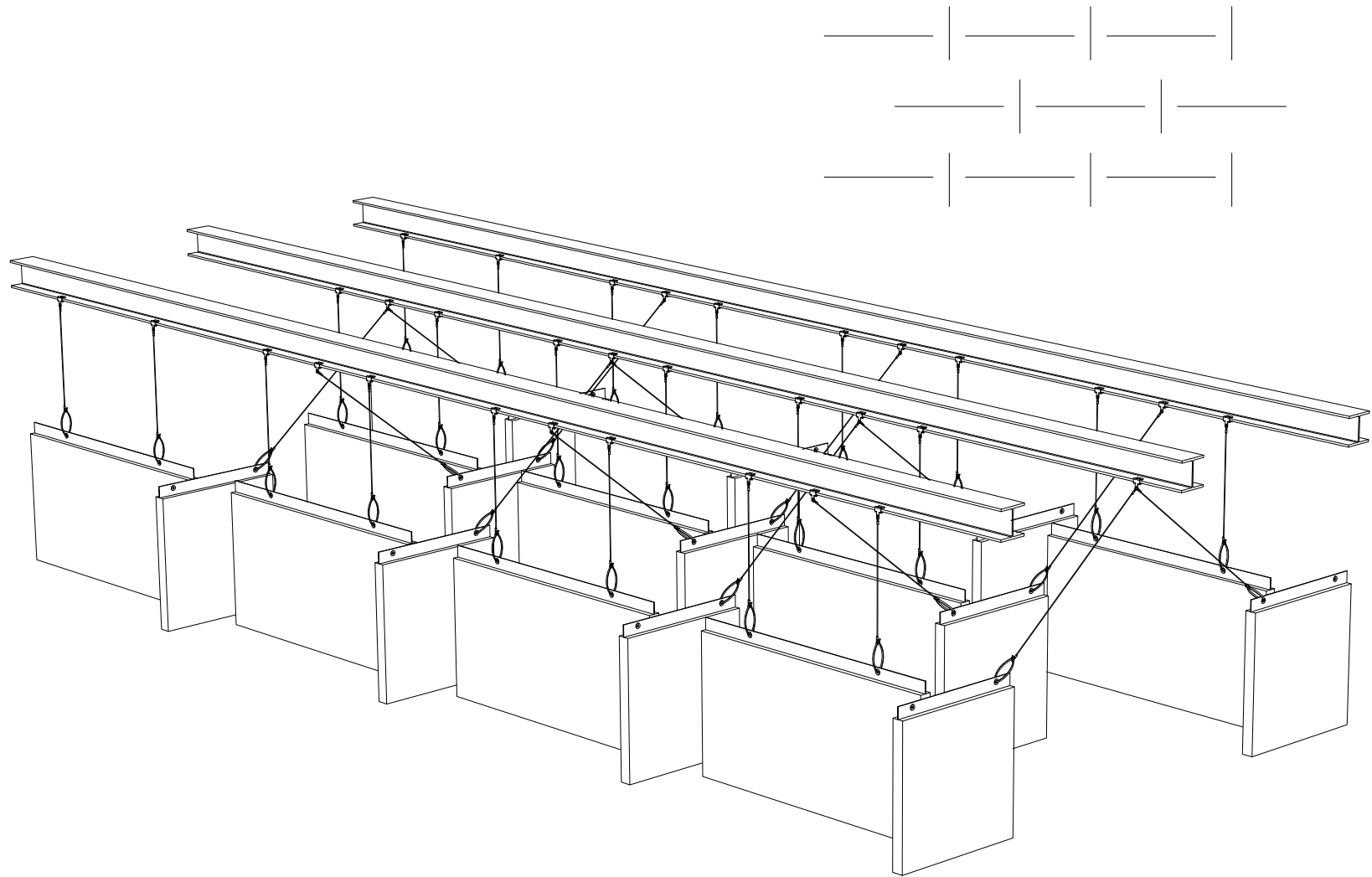

GORDON[®]
ARCHITECTURAL+ENGINEERED SOLUTIONS

5023 Hazel Jones Rd.
Bossier City, LA 71111
800.747.8954
GORDON-INC.COM
sales@gordon-inc.com

CREATIVE MATERIALS FOR ACOUSTICS
ACOUSTICAL BAFFLES
STAGGERED CONFIGURATION

TYPE A:
SLIGHT PUCKERING
ON FABRIC FACE

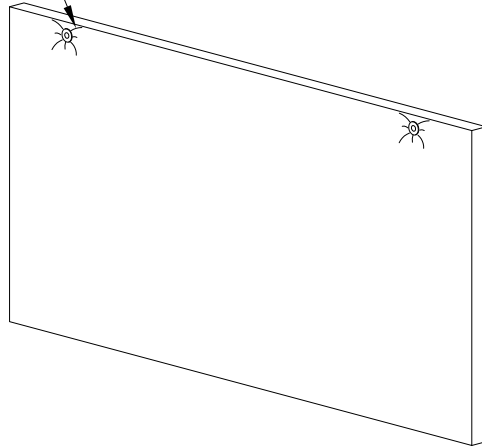

TYPE B:
CLEAN, SMOOTH
FACING

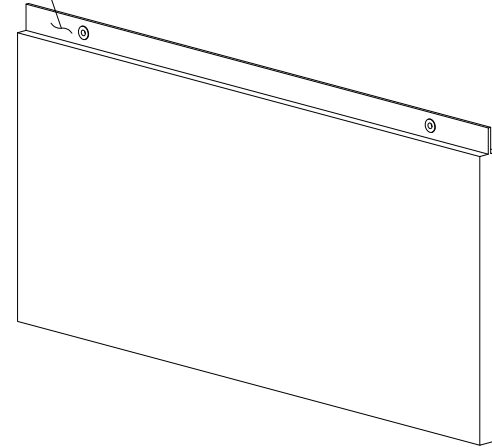

GORDON®
ARCHITECTURAL+ENGINEERED SOLUTIONS

5023 Hazel Jones Rd.
Bossier City, LA 71111
800.747.8954
GORDON-INC.COM
sales@gordon-inc.com

CREATIVE MATERIALS FOR ACOUSTICS
ACOUSTICAL BAFFLES
MOUNTING OPTIONS

VERTICAL SUPPORT SPACING EVERY 8' - 12'
DEPENDING ON THE WEIGHT OF THE BAFFLE

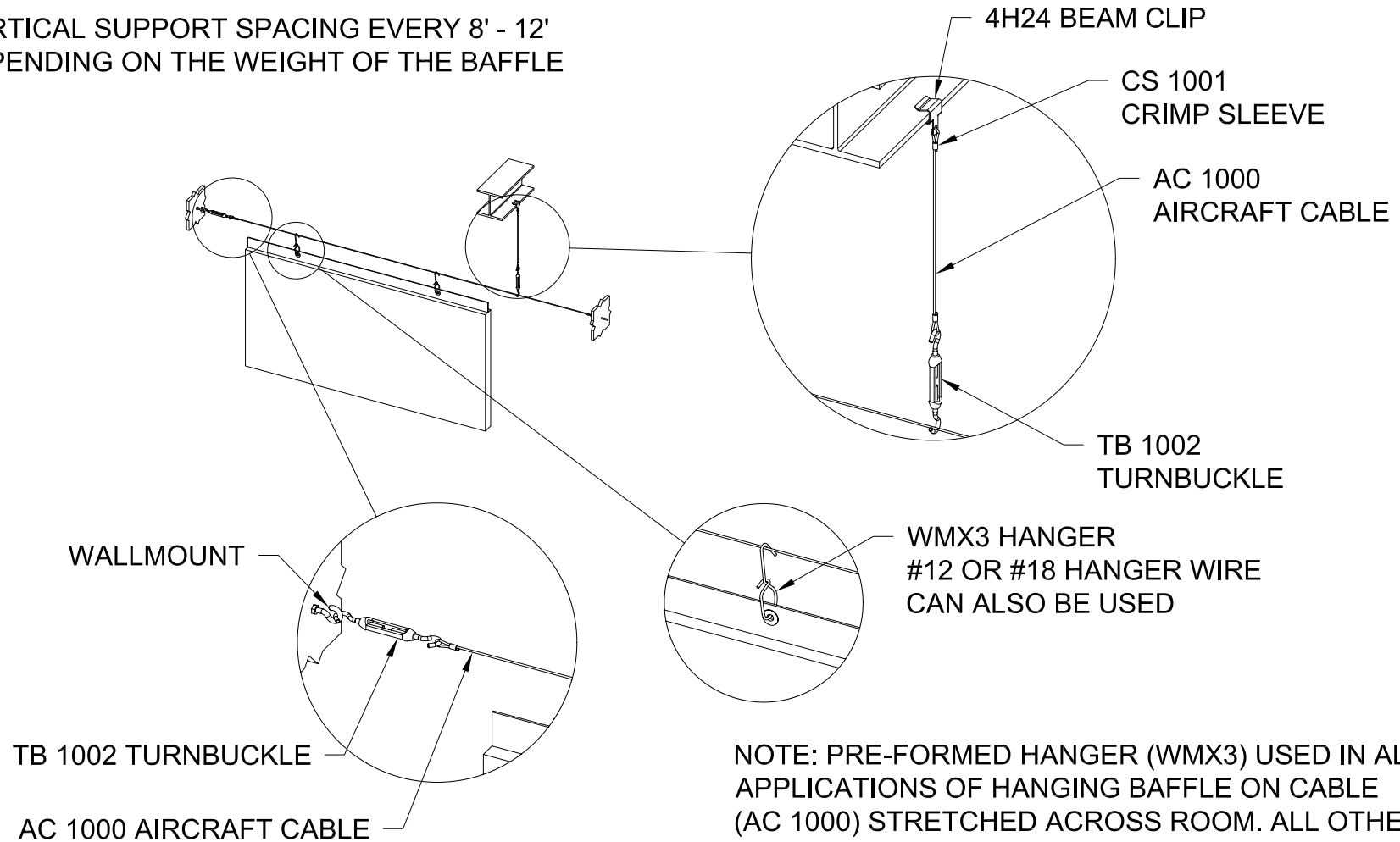

NOTE: PRE-FORMED HANGER (WMX3) USED IN ALL APPLICATIONS OF HANGING BAFFLE ON CABLE (AC 1000) STRETCHED ACROSS ROOM. ALL OTHER APPLICATIONS USE NYLON TIE WRAPS (TR 500)

GORDON[®]
ARCHITECTURAL+ENGINEERED SOLUTIONS

5023 Hazel Jones Rd.
Bossier City, LA 71111
800.747.8954
GORDON-INC.COM
sales@gordon-inc.com

CREATIVE MATERIALS FOR ACOUSTICS
ACOUSTICAL BAFFLES
HANGER DETAILS