

Gordon Partition Wall (Metric)

Required Tools:

- Alignment tools
 - Laser level,
 - Rotary laser level,
 - Mason's twine, or
 - 1200mm level
- Drills and screw drivers with bits for installing # 2 Phillips head screws.
- 16mm socket with extension for installing top rail.
- Soft rubber mallet
- Non-permanent markers, graphite pencils, and chalk line.
- Saws that have the appropriate blade for cutting aluminum.

NOTE: Other tools may be required for installing brackets to floor depending on fasteners chosen to attach floor brackets.

Partition Wall (Metric) Installation Instructions:

1. Install top rails per required layout attached to grid ceiling through 10mm X 38mm slots **FIG.1**. Verify alignment of top rail with a construction line laser, a string line, or erasable locating marks. Match part coding and parts to layout legend.

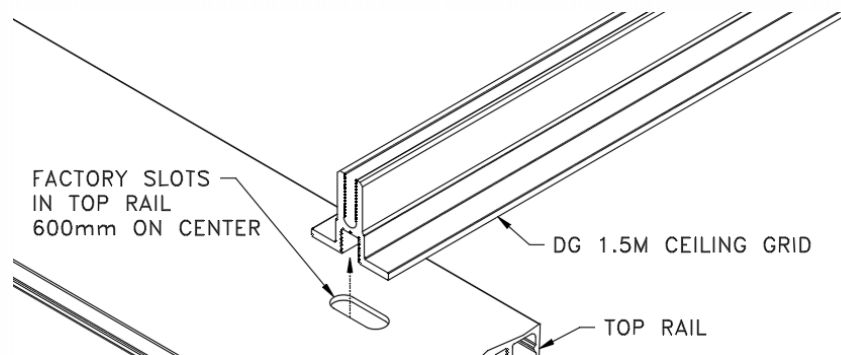

FIG.1

2. The centerline location of the floor bracket is 38mm from the inside edge of top rail. Project the centerline of the top rail slotted holes to the floor. Mark a line with a visible, erasable mark, a chalk line, or a construction line laser. This defines the centerline of the floor brackets.

3. Locate floor bracket per layout aligned with center of top rail. The floor brackets have locating notches to aid in centering post on established locations. Note orientation of mating parts **FIG.2**.

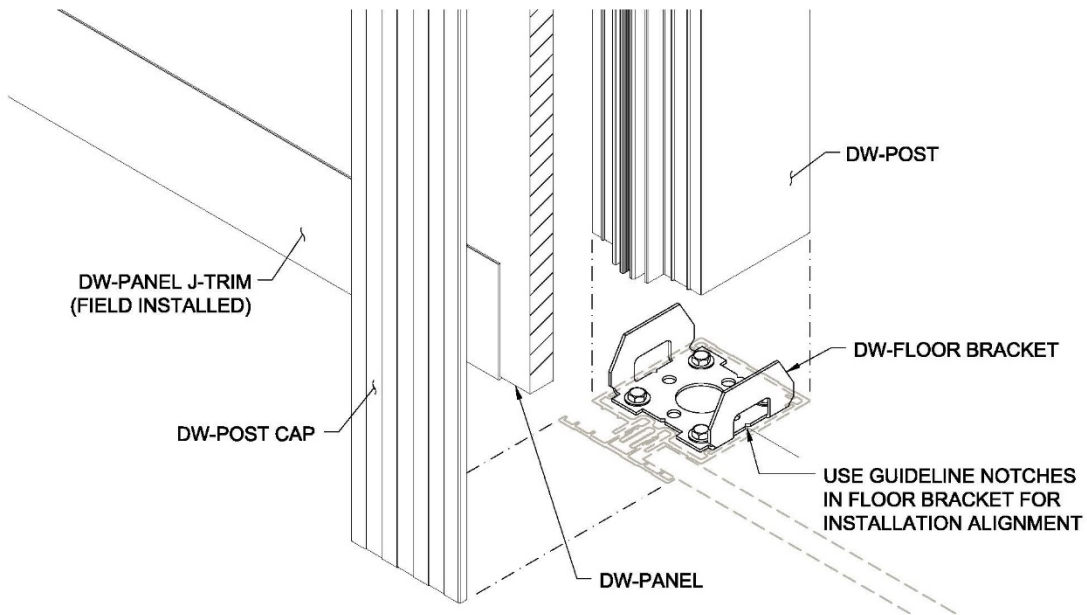

FIG.2

The first floor bracket will be installed 38mm on center from start wall. (Approximately 3mm from wall to edge of bracket.) **FIG.3** Fasten to floor with the appropriate fasteners for flooring material. Continue installing the floor brackets in line with the top rail on 1200mm centers. As shown in layout **FIG.3**.

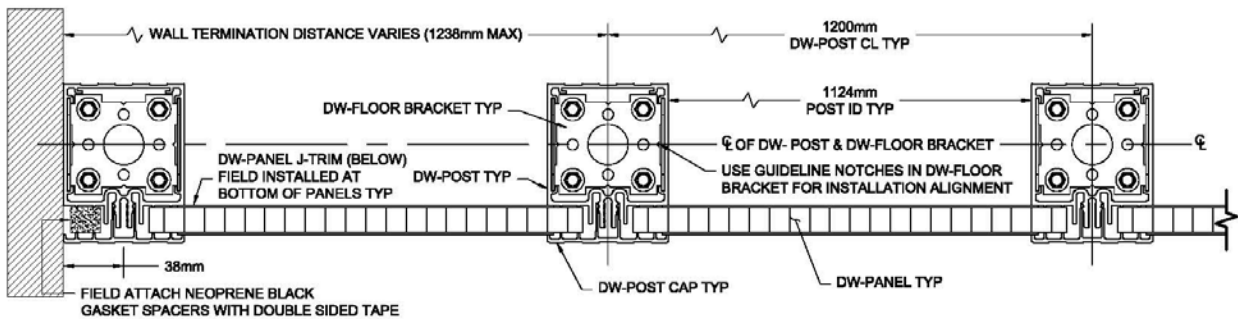

FIG.3

4. After the top rail and floor brackets are installed the post installation may start. All posts have two top brackets, except the start and end post located next to a wall, which use only one on the side opposite of wall. The brackets slide into the bracket guides. **FIG.5. & 6.**

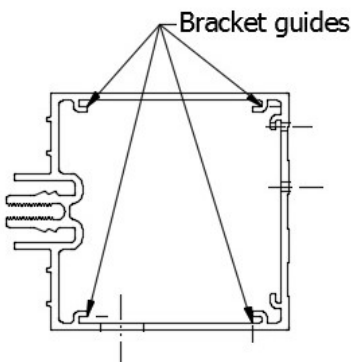

FIG.5

Install post over floor bracket next to wall. Align top bracket holes with top rail screw bosses and fasten with supplied 1/4-20 X 3/8" bolts. Repeat process using two top brackets per intermediate post. One on each side as shown in **FIG.6.**

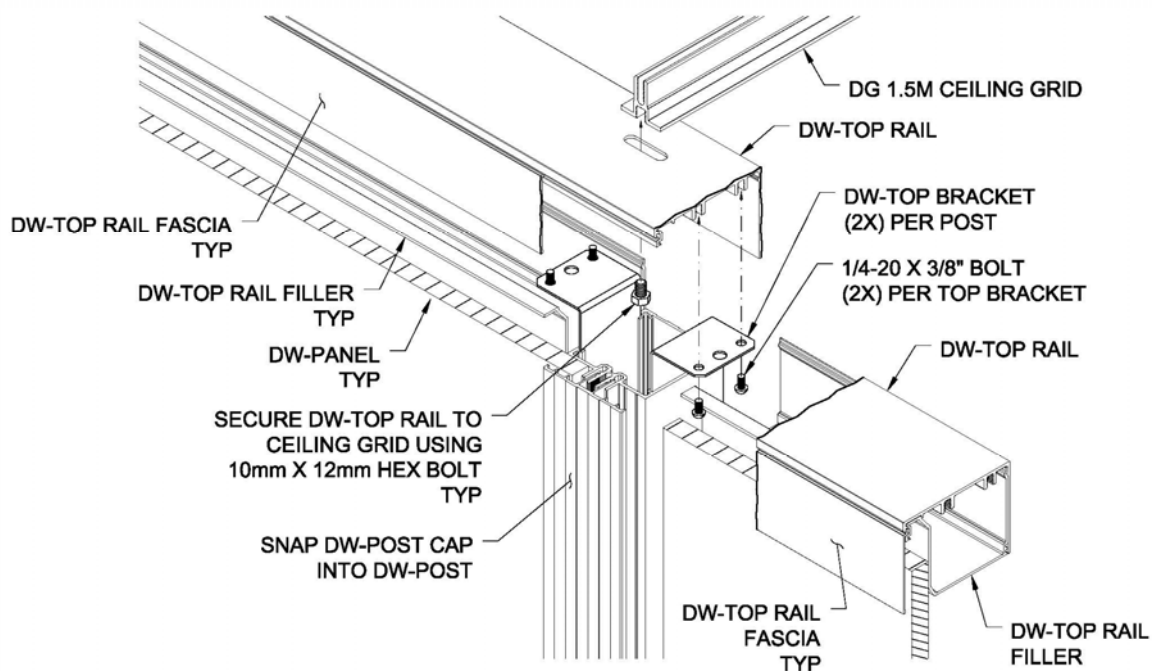

FIG.6

Note: It is important to maintain 1124mm distance between posts at top for installing factory cut top rail filler **FIG.7**.

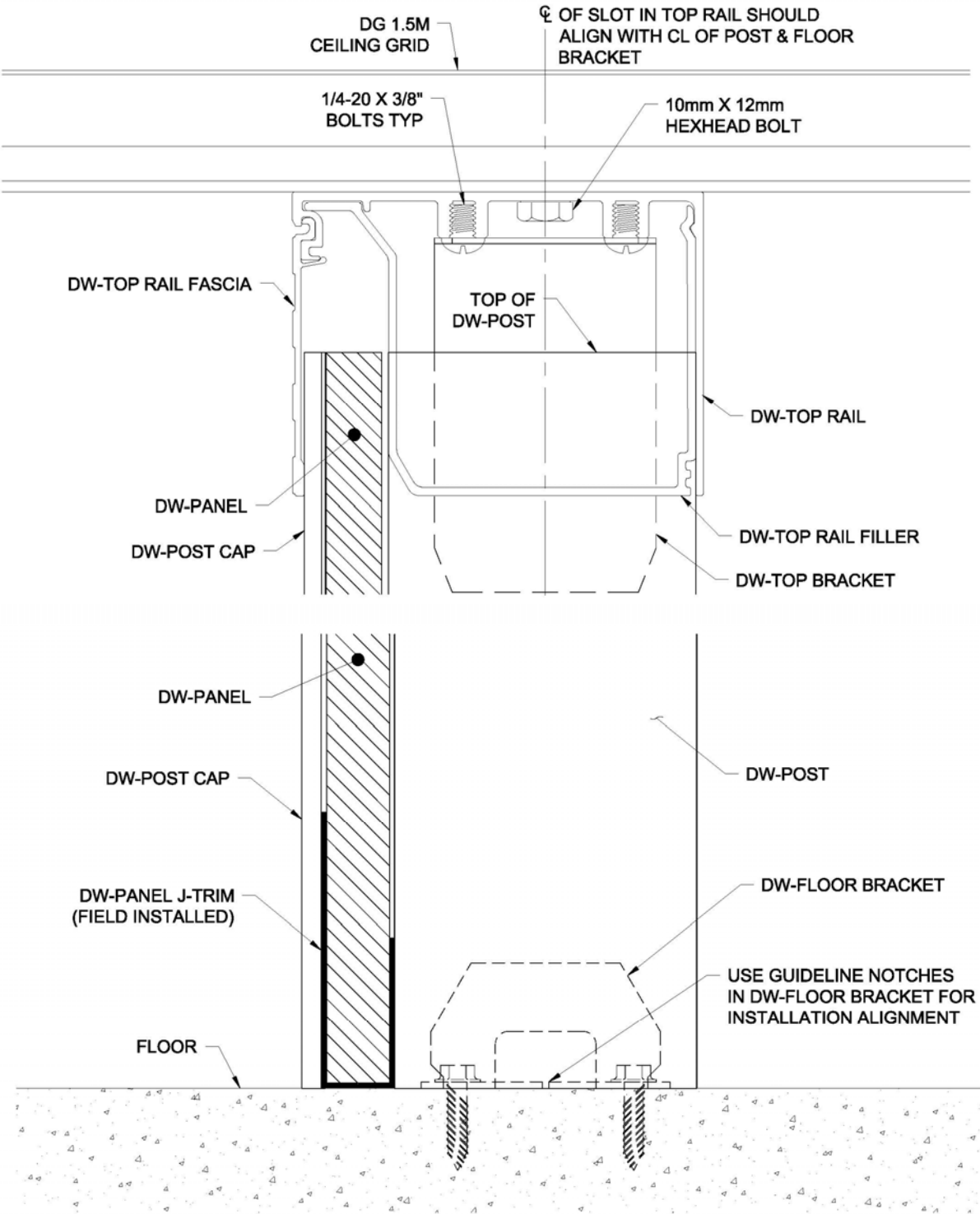

FIG. 7

- 5. Install top rail fillers. For ease of installation, it helps to engage the filler lip in the top rail at about a 10° angle then bump in place with heel of hand.

6. Install panels. Peel protective coating about 80mm away from edges of panels on both sides. Slip J-Trim on bottom edge center of panel. Place panels in position between posts. Place post cap in position at floor. Use a rubber mallet to impact post cap and snap in place. Start at floor working toward ceiling.
7. The Partition Wall panels are factory cut to fit 1200mm on center post. The final panel terminating at end wall may require field cutting. The panel can be cut with a table or circular saw. The width of the terminating panel is the measurement between post centers minus 45mm.

Note: At wall contact a 150mm long neoprene filler will be supplied to fill panel pocket void at top, middle and bottom of post. This helps the post cap maintain a uniform engagement **FIG.3**.

8. Install the Top Rail Trim supplied in 2438mm long pieces by snapping into top rail. **FIG.6 & 7**.

Partition Wall (Metric) Components

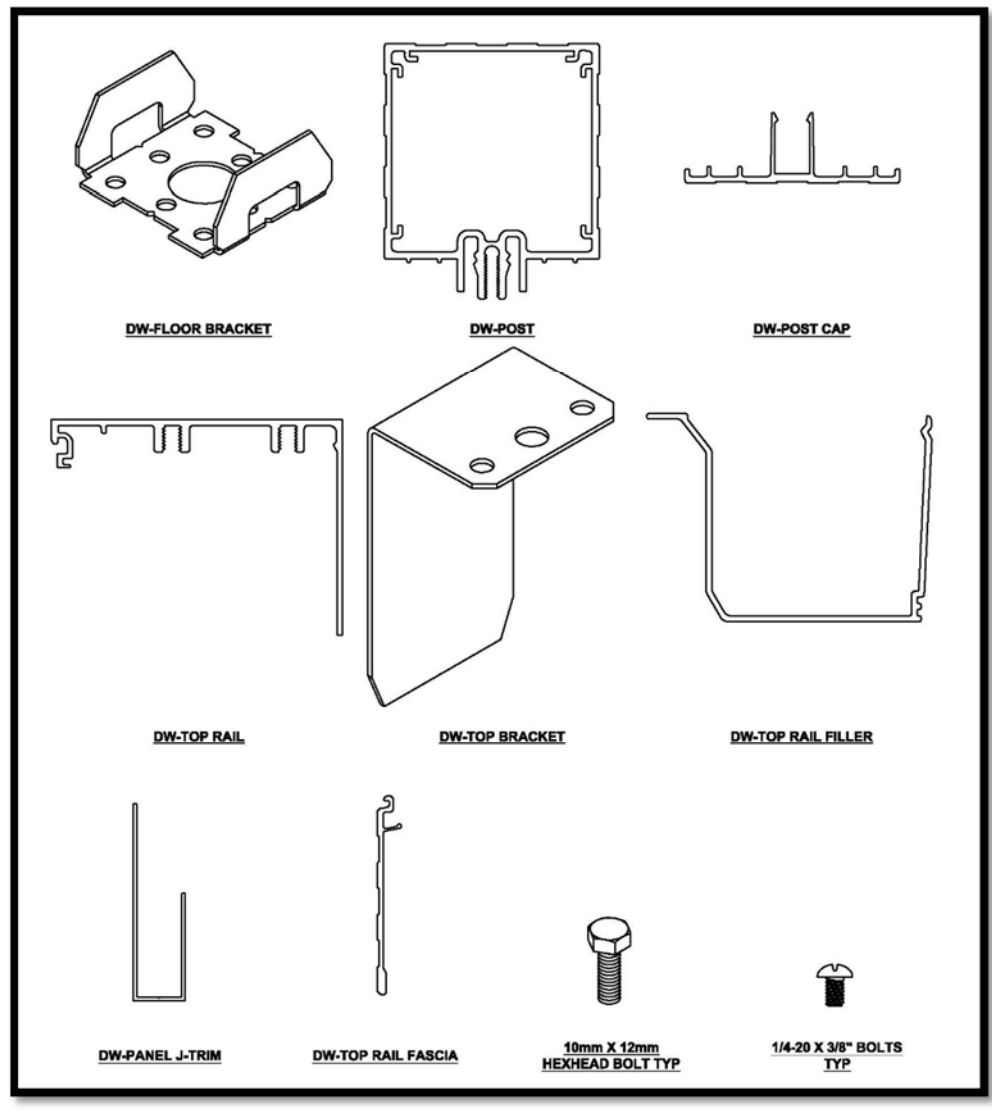

Partition Wall Maintenance:

Cleaning Powder Coated, Anodized, and Polyvision Ceramic Steel Finished Products:

Gordon's clear anodized and powder coated aluminum products may be kept clean and bright using the following steps:

1. For normal cleaning, a soft cloth with mild soap and water should be used. Material should have excess water wiped off.
2. If cleaning has been postponed for an extended period time and/or a tough "stain" is visible, first follow step one above. If this does not sufficiently clean the material, you should use a soft cloth with a 50-50 mixture of water and Isopropyl Alcohol. Material should have excess liquid wiped off.
3. If step one and two above is still not sufficient, you may use the 50-50 mixture of water and Isopropyl Alcohol with a small amount of "Comet" dabbed on the cloth. The damp cloth with the "Comet" should be used in a circular motion being careful not to rub too hard and leave scratches in the finish. Once done, the material must be wiped clean with a damp cloth to remove any "Comet" residue.

Cleaning twin wall polycarbonate panels:

Use a warm soapy (mild liquid dish soap) water to clean polygal sheets. Wipe with a soft, clean lint-free cloth dampened with the soapy water. Wipe panel again with a lint-free cloth dampened with water only to remove soap residue. Dry with a soft cloth.

Cleaning procedures should be initiated as soon as practical after completion of installation to remove construction soils and accumulated soils from handling.