

PERIMETER POCKETS



APPLICATIONS

- Ceiling transition to perimeter wall
- Conceals blinds, curtains, draperies, shades and screens
- Air return or supply
- Perimeter & ceiling transition lighting

DESIGN ELEMENTS

- Available in extruded aluminum and brake form aluminum or steel
- Costs less than drywall construction
 - Avoids the high labor cost of furring, taping, filling and painting.
 - All pockets can be pre-cut to size, pre-finished and completely fabricated ready to install.
- Integrates with suspended drywall or acoustical ceiling systems
- Provides structural support for shade pockets and can include removable closures for access
- Can integrate with lighting and provide an economical solution to traditional, high-cost light fixtures
- Available vented for HVAC
- Hanging & splicing
 - Hangers, splices, end closures, and corners are designed for exact alignment and simple installation
- Pre-Finished
 - Standard finishes that match all major grid manufacturers
 - Custom finishes



COMMUNITY COLLEGE OF BALTIMORE COUNTY LEARNING CENTER
Catonsville, MD

BRAKE FORM POCKET - Aluminum or Steel

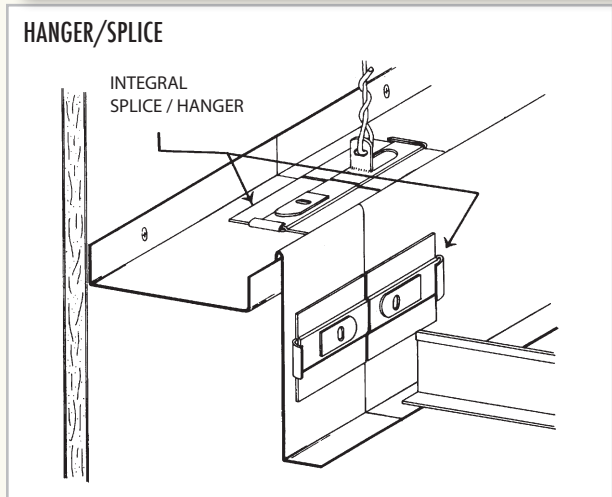
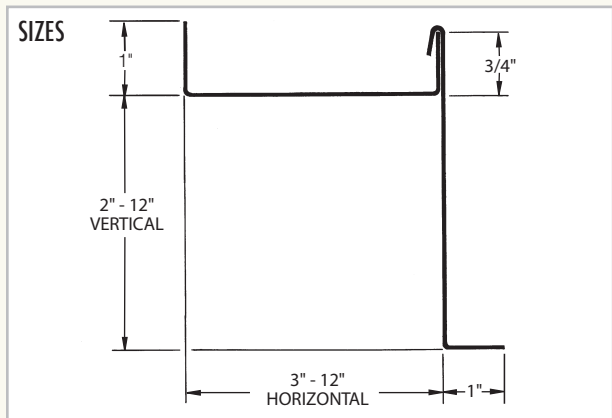

WILLIAM P. HOBBY AIRPORT
Houston, TX

PERIMETER POCKETS

EXTRUDED ALUMINUM POCKETS

CPA PROFILES

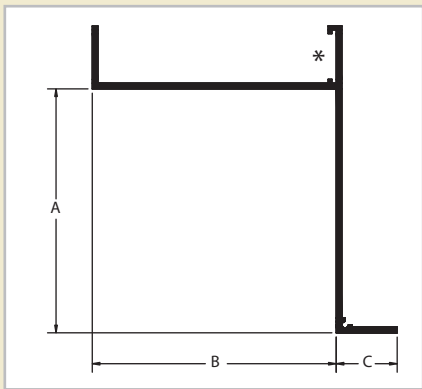

TYPE	A	B	C
CPA-3030*	3"	3"	15/16"
CPA-4040	4"	4"	1"
CPA-4515	1-1/2"	4-1/2"	3/4"
CPA-4525	2-1/2"	4-9/16"	3/4"
CPA-4540	4"	4-1/2"	3/4"
CPA-5050	5"	5"	1-1/16"

The chart above are profiles of similar shape like the CPA Profiles drawing to the left. *No Splice Boss is included in the CPA-3030 profile. See Website for the actual drawings of these profiles.

CPA-4515R

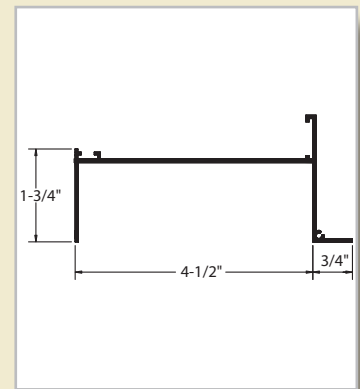

CPA-4045

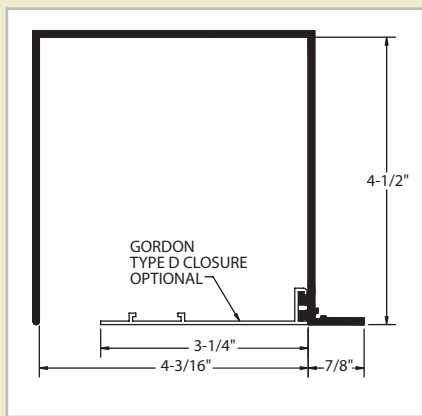

CPA-4550R

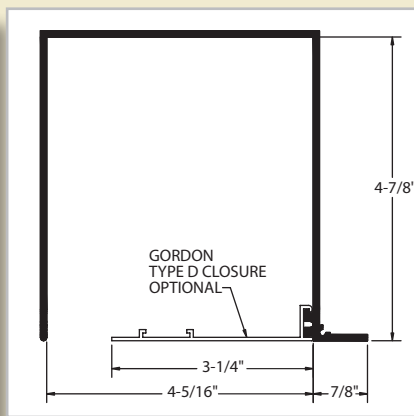

CPA-3050

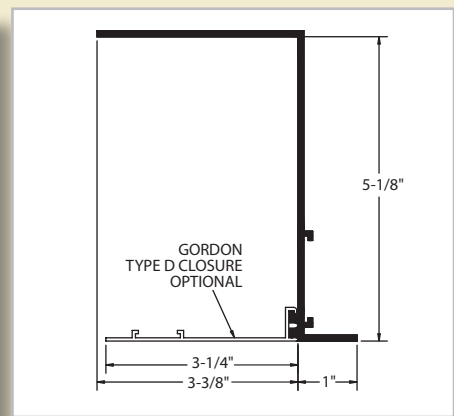

CPA-3540

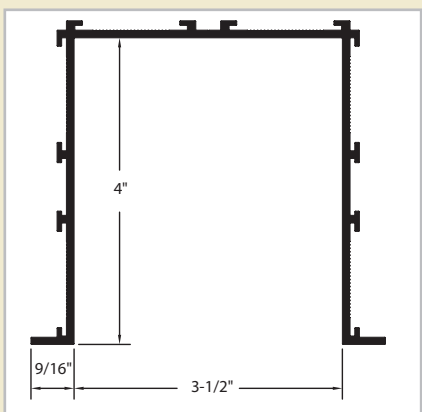

EDS ANGLE

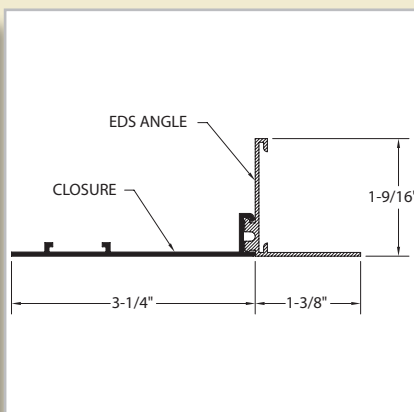

ROLLER SHADE MASK

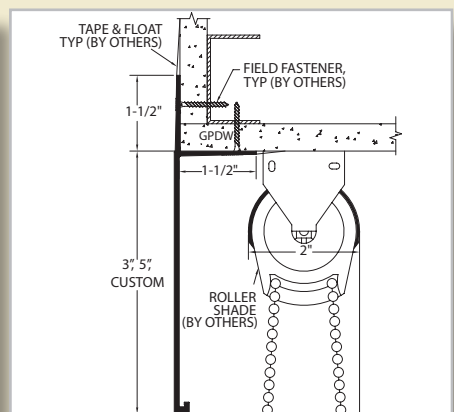

TWO-PIECE EXTRUDED ALUMINUM POCKETS

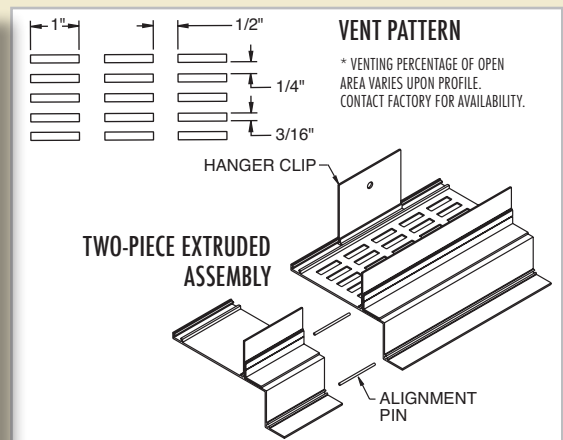
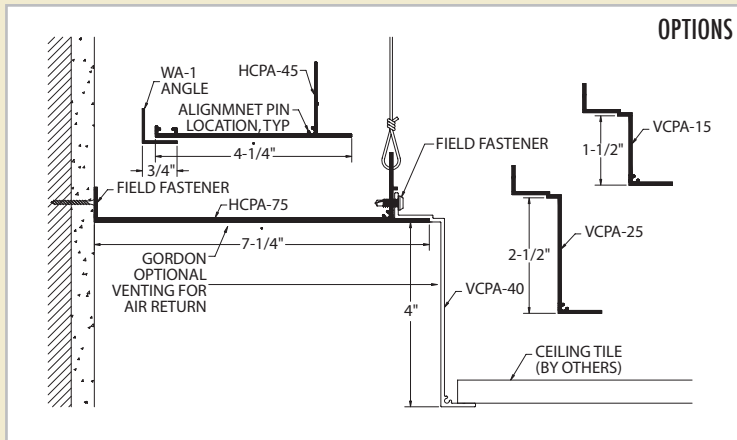

DETAILS

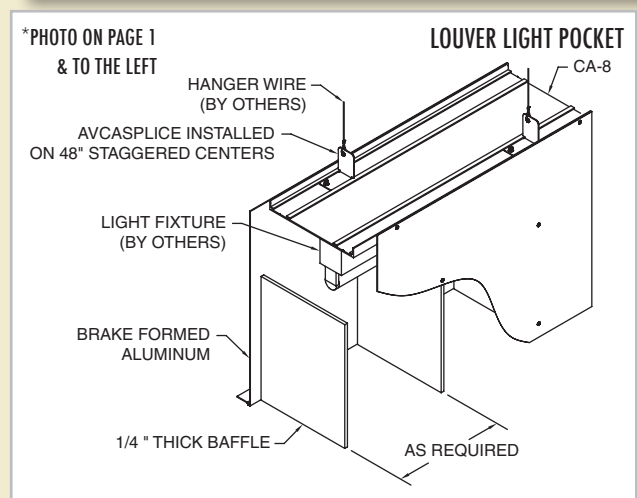
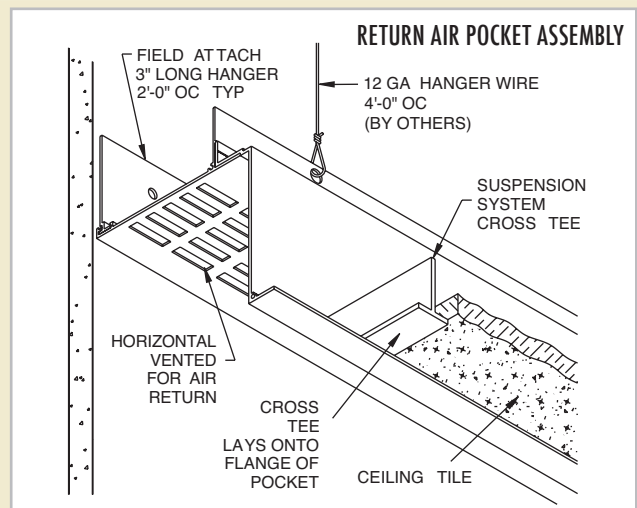
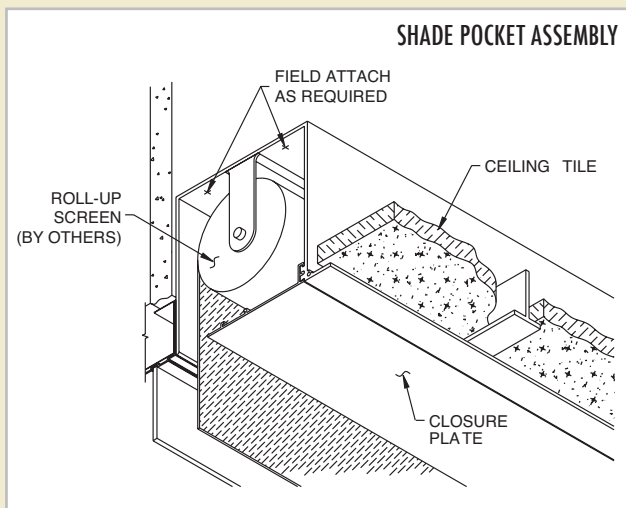

DETAILS

DRYWALL/LIGHT ASSEMBLY

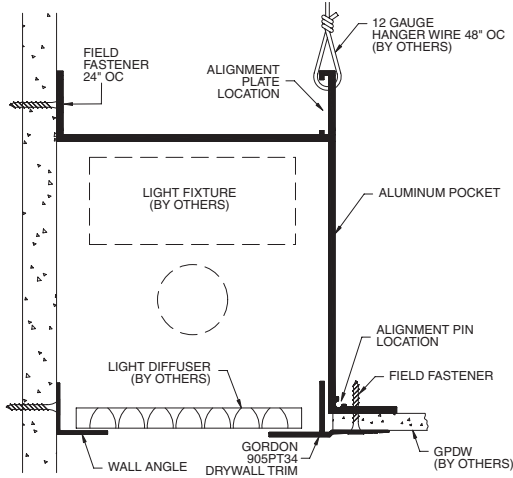

WELDED CORNERS

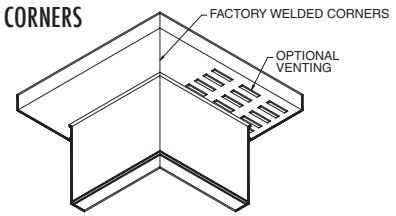

END CAPS

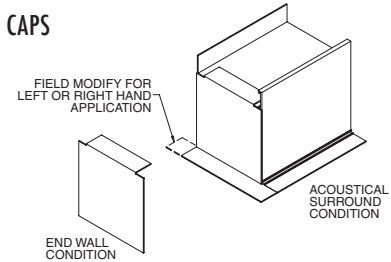

WE WELCOME CUSTOM PROFILES. CONTACT GORDON FOR MORE INFORMATION.

FINISHES

- Powder Coats
 - Standard
 - ACROGUARD® Enhanced Durability
 - ACROGUARD® Textured
 - ACROGUARD®-UVX Durable Exterior
 - ACROSTAT™ Antimicrobial
- Acrylic Water Base "Wet" Paints
 - Standard
 - Custom Matched
 - Textured
- PVDF Organic Coatings
 - 50% Resin-based
 - 70% High Performance Resin-based

GREEN BY DESIGN

- Products contribute to LEED®¹ certification
- 38.1% recycled aluminum extrusions
 - 29.4% pre-consumer content
 - 8.7% post consumer content
- Aluminum Coil - 19% recycled
 - 18% pre-consumer content
 - 1% post consumer content
- Steel Coil - 61.4% recycled
 - 10.5% pre-consumer content
 - 50.9% post consumer content
- In-House Finishes
 - Biodegradable pre-treatment (No phosphates)
 - No hazardous waste
 - No VOCs
 - No heavy metals
- Reference our sustainable products brochure and website for more information. Recycled content values are subject to change. Contact us for accurate values or job specific requirements.

GORDON[®]
INCORPORATED

5023 HAZEL JONES ROAD, BOSSIER CITY, LA 71111
800.747.8954
800.877.8746 FAX
SALES@GORDON-INC.COM
GORDON-INC.COM
AN EMPLOYEE OWNED COMPANY

¹ LEED® is a registered trademark of the U.S. Green Building Council.

