

MILLENNIUM[®]

WALL SYSTEMS



CISCA Construction Excellence Award Winner

MADISON SQUARE GARDEN
New York City, NY



INSIDE PARKING GARAGE



OUTSIDE PARKING GARAGE

CAPSTAR AT COMPASS PLAZA
Austin, TX

MILLENNIUM[®]

WALL SYSTEMS

DESIGN ELEMENTS

MATERIAL:

- .063" aluminum or 18 ga. galvanized steel expanded to 1/4" thick tubular pattern
- Approximately 40% open area

PANEL SIZES:

- Stock sizes: 4' & 5' wide x 8', 10', & 12' lengths
- Factory fabricated to the desired size
- Custom sizes up to 5' x 14'

ACOUSTICAL MEDIA:

- Encapsulated fiberglass pads
- Non-woven acoustical fabric
- NRC ranges from 0.70 to 1.10



CALIFORNIA STATE UNIVERSITY
Los Angeles, CA

APPLICATIONS

- Flat or curved walls
- Corrugated walls
- Screenwalls
- Sunscreens
- Facades
- Can be backlit to create dynamic visual effects

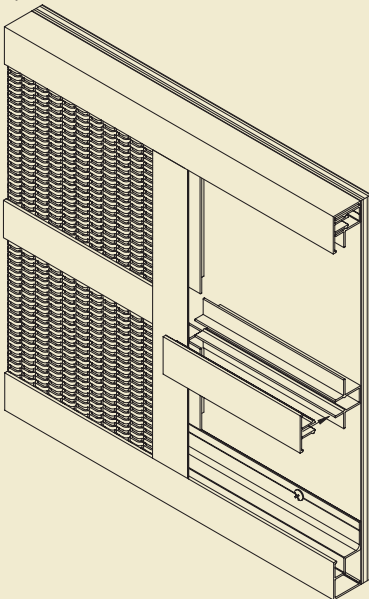

GRIFFITH PARK OBSERVATORY
Los Angeles, CA



OFFICE OF PUBLIC HEALTH
Baton Rouge, LA

TRIM OPTIONS

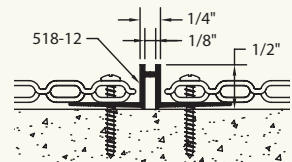
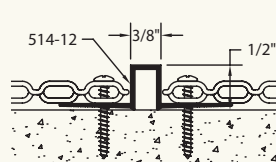
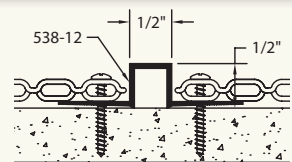
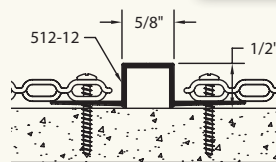
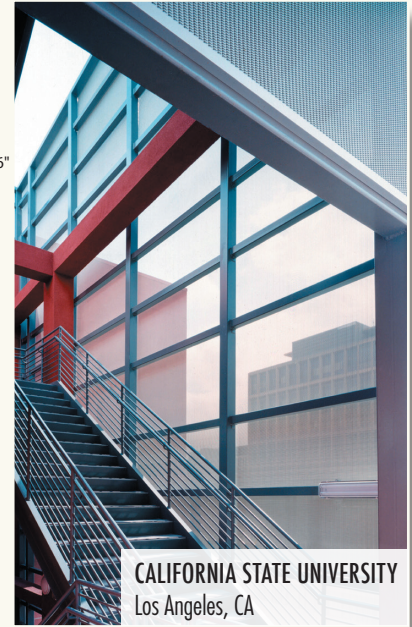
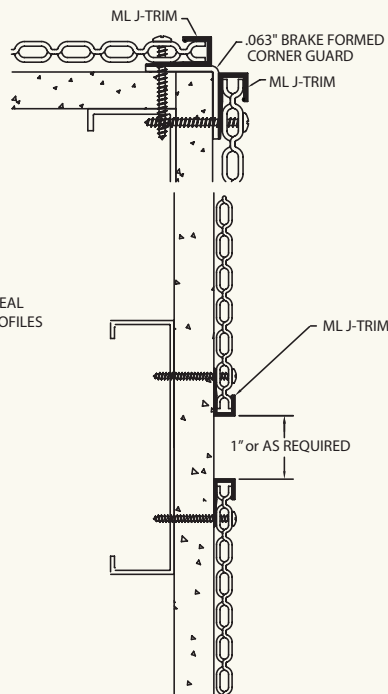
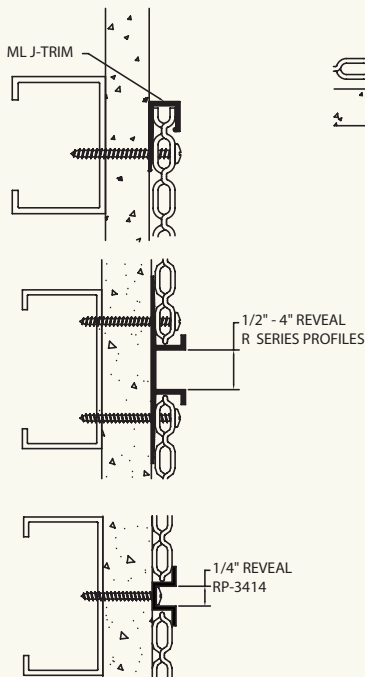
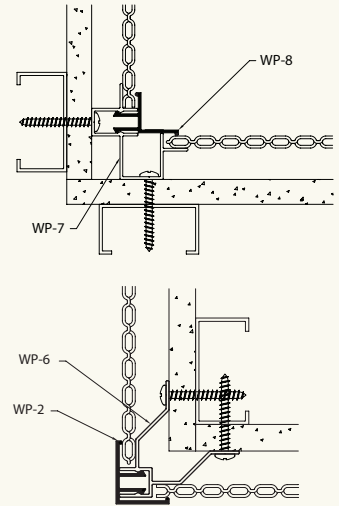
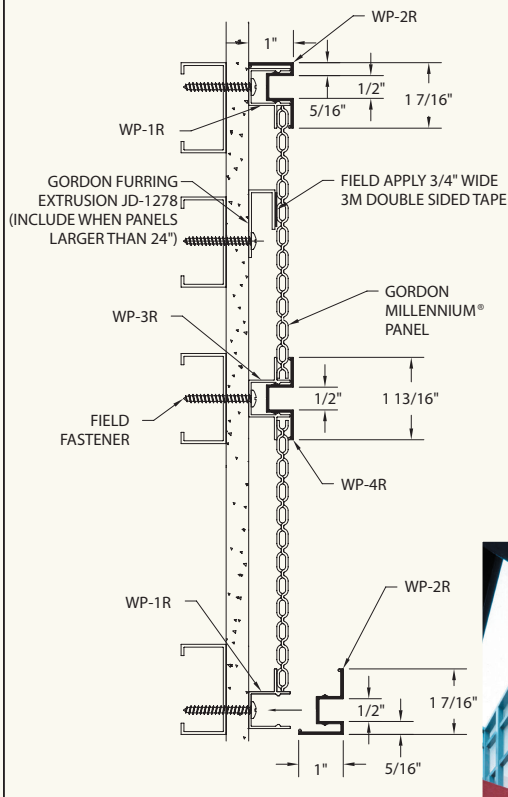
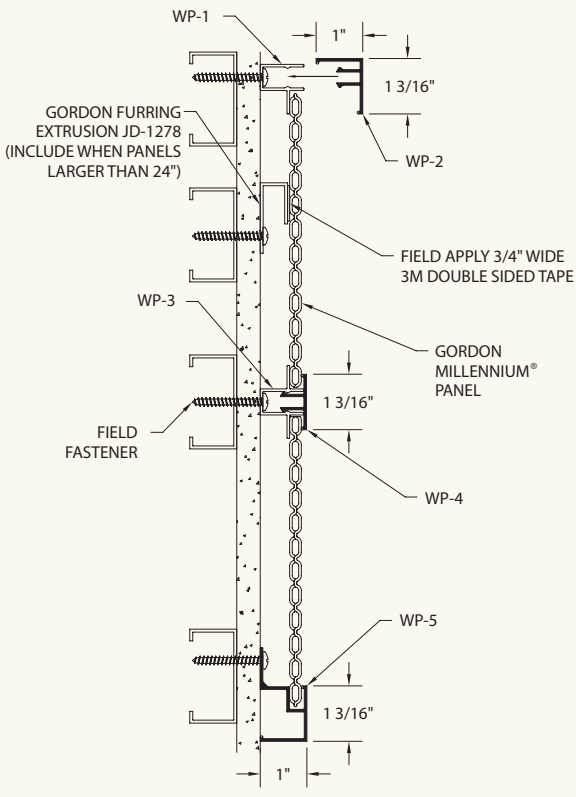



BUSH INTERCONTINENTAL AIRPORT, TERMINAL E
Houston, TX

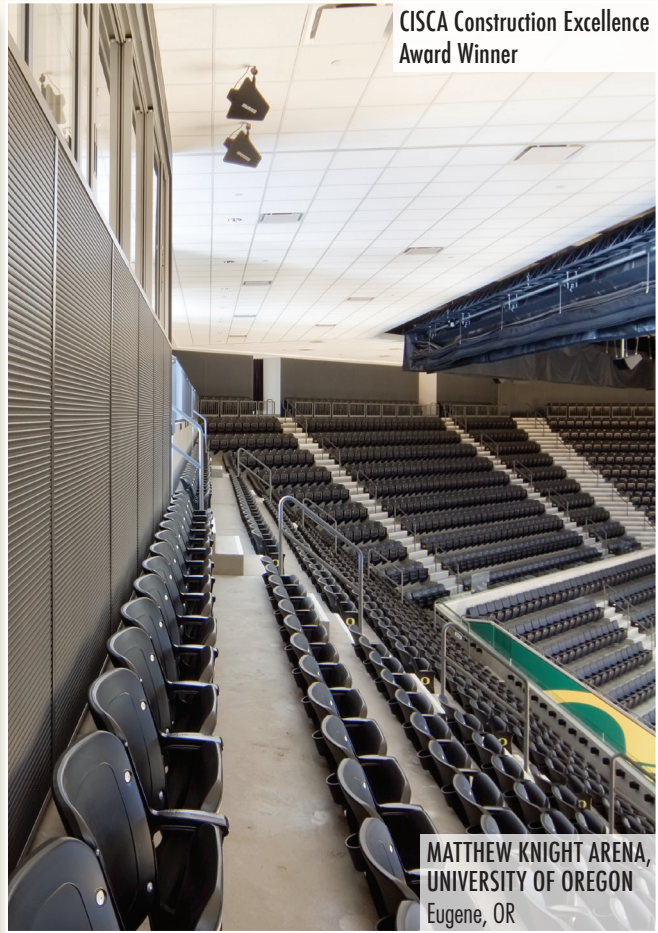

CISCA Construction Excellence Award Winner

MATTHEW KNIGHT ARENA,
UNIVERSITY OF OREGON
Eugene, OR

FINISHES

- Custom and Standard Powder Coats
- Specialty Powder Coats
 - ACROGUARD®-UVX
 - ACROGUARD®
 - Metallic
- Specialty Exterior Finishes

GREEN BY DESIGN

- Products contribute to LEED®¹ certification
- 26% recycled aluminum coil
 - 23% pre-consumer content
 - 3% post consumer content
- In-House Finishes
 - Biodegradable pre-treatment (No phosphates) powder coat
 - No hazardous waste
 - No VOCs
 - No heavy metals
- Reference our sustainable products brochure and website for more information



5023 HAZEL JONES ROAD, BOSSIER CITY, LA 71111
800.747.8954
800.877.8746 FAX
SALES@GORDON-INC.COM
GORDON-INC.COM
AN EMPLOYEE OWNED COMPANY

¹ LEED® is a registered trademark of the U.S. Green Building Council.

