

SIMPLY AHEAD OF THE CURVE

CleanCove™

by **GORDON**
CLEANROOM PRODUCTS DIVISION

Simple and cost effective, the CleanCove™ by Gordon is the first off-the-shelf product available for making a curved transition from ceiling-to-wall and from wall-to-wall at inside corner locations.

Today's changing cleanroom design requirements for Life Science industries increasingly demand greater filter coverage than is achievable utilizing the traditional approach of cut-out openings in painted drywall ceilings. While today's ceiling grid products offer a practical solution for most cGMP facility applications, the 90-degree intersection of ceiling-to-wall has remained a design challenge—until now. The CleanCove by Gordon answers this need.

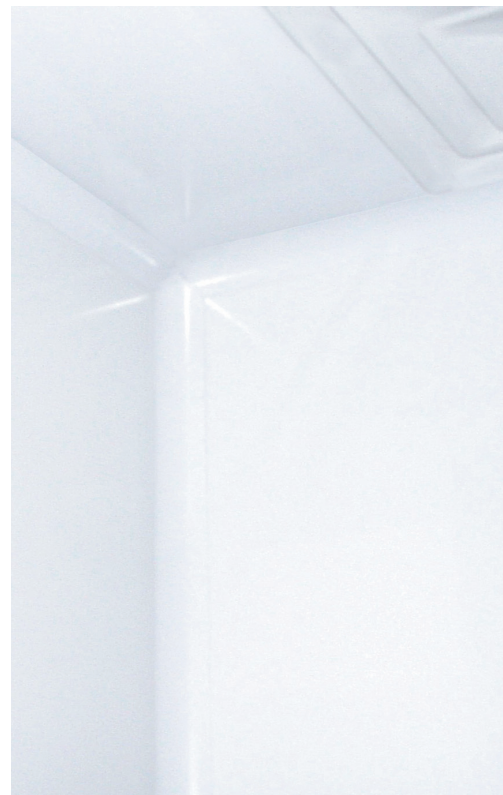

Eliminating 90-degree corners with CleanCove helps assure that your cGMP facility will be validatable. CleanCove is compatible with new construction or retrofit applications, easily upgrading existing facilities to cGMP compliance.

With minimal effort, the three part CleanCove system provides a smoothly rounded, easy to clean curved transition from ceiling-to-wall and at wall-to-wall inside corners. Extruded aluminum coves snap into vinyl anchor strips, and welded 3-way inside corner assemblies make perfectly finished junctures at the complex inside ceiling corner and wall intersections.

SIMPLY AHEAD OF THE CURVE

Installation as **easy as 1 - 2 - 3 . . .**



1. The vinyl anchor strip is affixed into the corners around the ceiling perimeters and the inside corner(s) of the walls.



2. The factory fabricated 3-way inside corner assemblies snap into the vinyl anchor strips

Finally, the entire **CleanCove™** installation is completed by applying a bead of caulk sealant along edges and seams creating a smooth, sealed cove around the entire room.



3. The field cut-to-fit straight lengths of coving snap securely into place.

TYPICAL CEILING TRANSITION

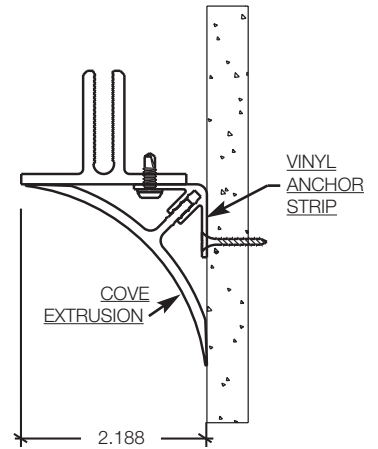

Durable extruded aluminum **CleanCoves** and corners are finished in our standard white powder coat that combines premium appearance and high chemical resistance.

CleanCoves are 12 feet long and packaged 10 per carton, complete with 12 feet long vinyl anchor strips.

***CleanCove™** is compatible with all of Gordon's Cleanroom Ceiling Systems. Consult your Gordon Cleanroom representative for all your cleanroom needs.*

GORDON
CLEANROOM PRODUCTS DIVISION

P.O. Box 4347
Shreveport, Louisiana 71134
5023 Hazel Jones Road
Bossier City, Louisiana 71111

Tel: 888.315.1561
Fax: 800.877.8746
www.gordongrid.com
sales@gordongrid.com