

FINAL FORMS

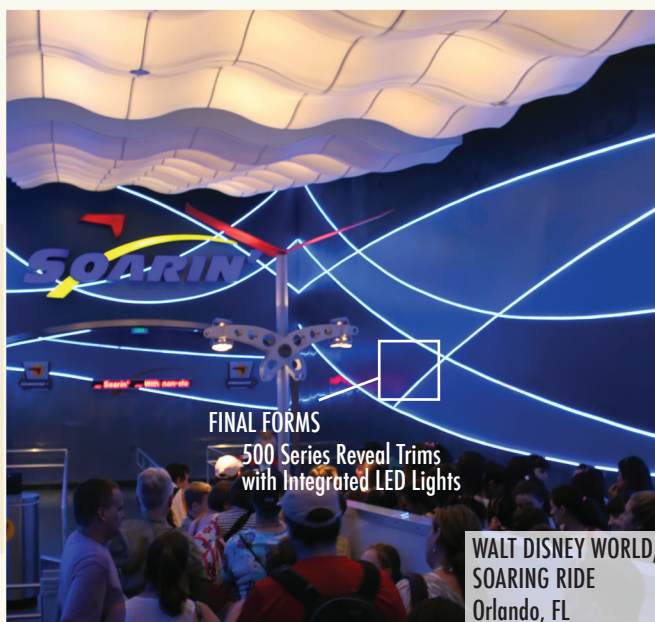

FINAL FORMS

- Fabricated from extruded aluminum
- Trims provide detail to drywall, plaster and acoustical applications.
- Final Forms I & II profiles are provided in a clear anodized, paintable, or painted finish.
- Factory painting is available in an acrylic “wet” paint finish or powder coat finish.
- Metal trims are stronger, maintain their shape, and are less vulnerable to damage than non-metal alternatives.
- Extruded aluminum trims install straight and true.
- New trims can be created to meet your design requirements.
- Factory welded intersections, curving, venting, and custom mitering are available.
- Pre-fabricated components are quick and easy to install.
- Quick ship – most profiles ship within 24 hours of ordering.
- Largest selection of profiles in the industry
- Most profiles can be ordered **online**.
- Accessories include end caps, inserts for wall covering, and release sheets.



FACTORY CURVING

Extruded aluminum drywall and plaster trims may be factory curved to virtually any radius.

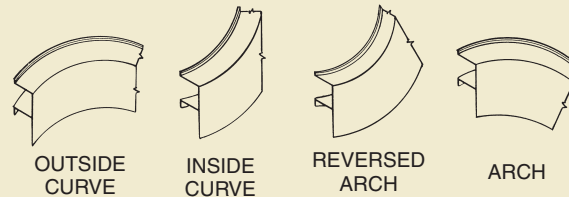

INTERSECTIONS

Gordon intersections provide ease of installation, avoids extra field cutting, and saves installation time. Parts are factory mitered and welded for a precise fit. We offer up to 12-way intersections.

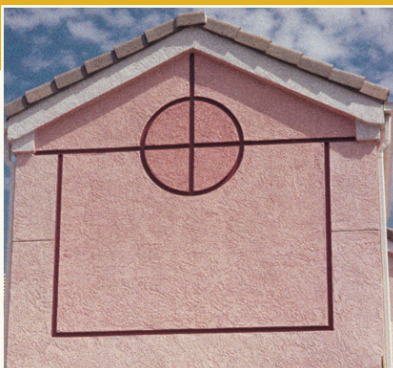
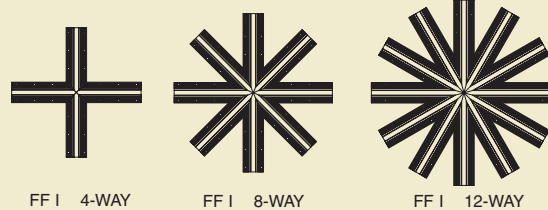

CUSTOM FABRICATION

Gordon is the leading provider of custom fabrication to meet the needs of any project requirement. Gordon offers unlimited finishing options, as well as custom curved materials and custom extrusions.

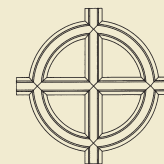

Intersection Detail

BUY ONLINE >

FINAL FORMS I - DRYWALL TRIMS

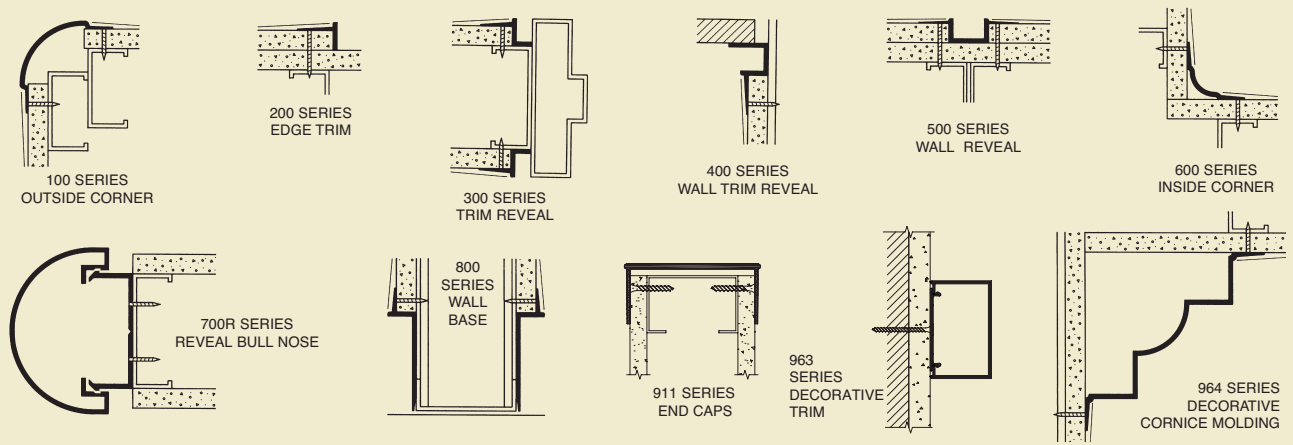

FINAL FORMS II - PLASTER TRIMS

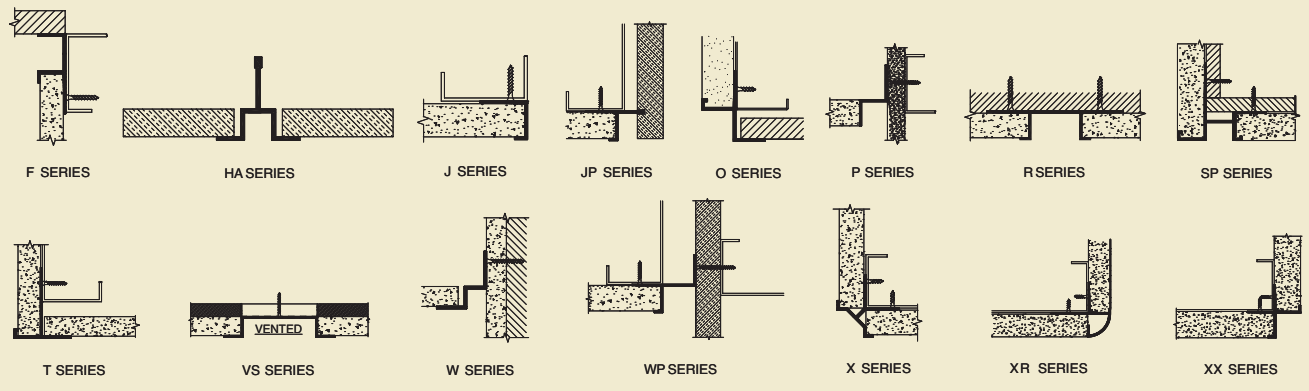

LIGHT COVES

Extruded aluminum light coves in stepped or radiused shapes install faster and are more economical than drywall or fiberglass reinforced gypsum.

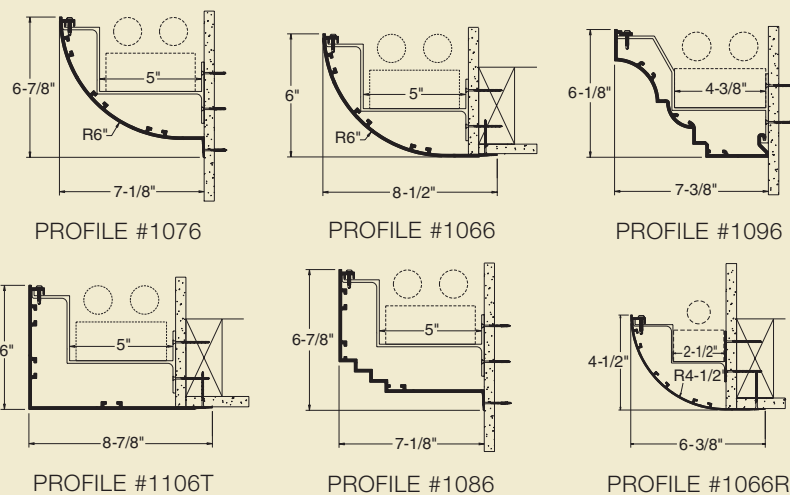

Shown is a small sample of our profiles, please visit our website for more information.





J-POP CENTER
San Francisco, CA

J-POP CENTER DETAIL

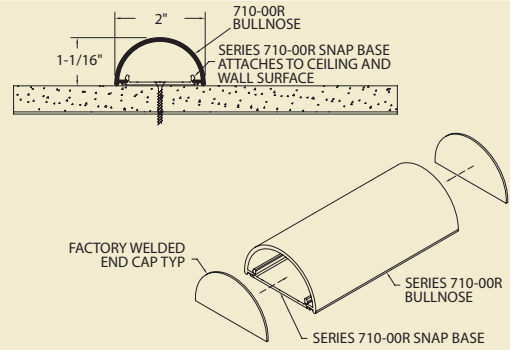

See photo on left



SHAPERY CENTER
San Diego, CA

GREEN BY DESIGN

- Products contribute to LEED®¹ certification
- 38.1% recycled aluminum extrusions²
 - 29.4% pre-consumer content
 - 8.7% post-consumer content
- In-House Finishes
 - Biodegradable pre-treatment (No phosphates) Powder Coat
 - No hazardous waste
 - No VOCs
 - No heavy metals
- Reference our sustainable products brochure and website for more information. Recycled content values are subject to change. Contact us for accurate values or job specific requirements.

BUY ONLINE ▶

GORDON[®]
INCORPORATED

5023 HAZEL JONES ROAD, BOSSIER CITY, LA 71111
800.747.8954
800.877.8746 FAX
SALES@GORDON-INC.COM
GORDON-INC.COM
AN EMPLOYEE OWNED COMPANY

¹ LEED is a registered trademark of the U.S. Green Building Council.

² Recycled Content Values vary from part to part. Contact Gordon for more information.

